



**浙江威能消防器材股份有限公司**

ZHEJIANG WINNER FIRE FIGHTING EQUIPMENT CO., LTD.

**嘉兴福新消防工业有限公司**

JIAXING FUXIN FIRE INDUSTRIAL CO., LTD.

★ 地址：浙江省嘉兴市南湖区凤桥镇新篁镇东路260号

Add: No. 260 Zhendong Road, Xinhuang Town, Jiashan City, Zhejiang 314008 P.R. China

Tel: +86-573-83144160 83147166 Fax: +86-573-83144260 83147266

E-mail: business@winnerfire.com.cn

<http://www.winnerfire.com.cn>



**WINNER**

Fire Fighting Equipment

**WINNER**





# 目录 CONTENTS



EN3-7 手提式干粉灭火器 Portable Dry Powder Fire Extinguisher	01-06
EN3-7 手提式干粉灭火器(内置式) Portable Dry Powder Fire Extinguisher(With Internal Cartridge)	07-08
EN3-7 手提式泡沫类灭火器 Portable Foam Fire Extinguisher	09-11
EN3-7 手提式泡沫灭火器 (内置式) Portable Foam Fire Extinguisher(With Internal Cartridge)	12-12
EN3-7 手提式清水灭火器 Portable Water Fire Extinguisher	13-13
EN3-7 手提式CO2灭火器 Portable CO2 Fire Extinguisher	14-16
EN1866-1 推车式灭火器 Mobile Fire Extinguisher	17-20
UL299 手提式干粉灭火器 Portable Dry Chemical Fire Extinguisher	21-22
CE 手提式灭火器 Portable Fire Extinguisher	23-24
CE 手提式灭火器 (内置式) Portable Fire Extinguisher(With Internal Cartridge)	25-26
CE 手提式CO2灭火器 (铝合金) Portable CO2 Fire Extinguisher (Aluminium-alloy)	27-28
CE 手提式CO2灭火器(合金钢) Portable CO2 Fire Extinguisher(Alloy-steel)	29-30
手提式干粉灭火器 Portable Dry Powder Fire Extinguisher	31-32
手提式CO2灭火器(铝合金) Portable CO2 Fire Extinguisher(Aluminum-alloy)	33-34
手提式CO2灭火器 (合金钢&碳钢) Portable CO2 Fire Extinguisher(Alloy-steel&Carbon-steel)	35-36
手提式灭火器(不锈钢) Portable Fire Extinguisher(Stainless Steel)	37-38
悬挂式干粉灭火器 Ceiling Dry Powder Fire Extinguisher	39-40
推车式灭火器 Mobile Fire Extinguisher	41-42
推车式灭火器(外置式) Mobile Fire Extinguisher(With External Gas Cartridge)	43-44
推车式CO2灭火器 Mobile CO2 Fire Extinguisher	45-46
正压式消防空气呼吸器 Self-contained positive pressure air breathing apparatus for fire fighter	47-48
储气瓶 Gas Cartridge	49-50
CO2高压阀门 CO2 High pressure valve	51-52
水基、干粉低压阀门 Water-based, Dry powder Low pressure valve	53-56
配件 Accessorie	57-63
雨淋阀 Sprinkler	64-64
卷盘 Hose Reel	65-65
水带 Fire Hose	66-66

# 荣誉 HONOUR





# EN3-7 手提式干粉灭火器

## Portable Dry Powder Fire Extinguisher



EN3-7 手提式干粉灭火器  
Portable Dry Powder Fire Extinguisher

型号	(Model):	MFZL1
外径	(Out-diameter):	Φ 85mm
容积	(Volume):	1.25L
瓶高	(Cylinder Length):	270mm
瓶重	(Cylinder Weight):	0.7Kg
灭火器重量	(Extinguisher Weight):	2.2Kg
灭火剂重量	(Dry Powder Filled Weight):	1Kg
温度范围	(Temperature Range):	-30℃~+60℃
最大工作压力	(Max. Working Pressure):	18bar
测试压力	(Test Pressure):	27bar
最小壁厚	(Min. Wall-thickness):	1.0mm
材料	(Material):	DC01/St12
灭火级别	(Fire Class):	8A 34B C
包装尺寸	(Packing Size):	10 × 10 × 36cm



型号	(Model):	MFZL1-1
外径	(Out-diameter):	Φ 85mm
容积	(Volume):	1.25L
瓶高	(Cylinder Length):	270mm
瓶重	(Cylinder Weight):	0.7Kg
灭火器重量	(Extinguisher Weight):	2.1Kg
灭火剂重量	(Dry Powder Filled Weight):	1Kg
温度范围	(Temperature Range):	-30℃~+60℃
最大工作压力	(Max. Working Pressure):	18bar
测试压力	(Test Pressure):	27bar
最小壁厚	(Min. Wall-thickness):	1.0mm
材料	(Material):	DC01/St12
灭火级别	(Fire Class):	8A 34B C
包装尺寸	(Packing Size):	10 × 10 × 36cm

# EN3-7 手提式干粉灭火器

## Portable Dry Powder Fire Extinguisher



EN3-7 手提式干粉灭火器  
Portable Dry Powder Fire Extinguisher

型号	(Model):	MFZL2
外径	(Out-diameter):	Φ 110mm
容积	(Volume):	2.5L
瓶高	(Cylinder Length):	310mm
瓶重	(Cylinder Weight):	1.1Kg
灭火器重量	(Extinguisher Weight):	3.7Kg
灭火剂重量	(Dry Powder Filled Weight):	2Kg
温度范围	(Temperature Range):	-30℃~+60℃
最大工作压力	(Max. Working Pressure):	18bar
测试压力	(Test Pressure):	27bar
最小壁厚	(Min. Wall-thickness):	1.07mm
材料	(Material):	DC01/St12
灭火级别	(Fire Class):	13A 55B C
包装尺寸	(Packing Size):	12 × 13 × 41cm



型号	(Model):	MFZL2-1
外径	(Out-diameter):	Φ 110mm
容积	(Volume):	2.5L
瓶高	(Cylinder Length):	310mm
瓶重	(Cylinder Weight):	1.1Kg
灭火器重量	(Extinguisher Weight):	3.7Kg
灭火剂重量	(Dry Powder Filled Weight):	2Kg
温度范围	(Temperature Range):	-30℃~+60℃
最大工作压力	(Max. Working Pressure):	18bar
测试压力	(Test Pressure):	27bar
最小壁厚	(Min. Wall-thickness):	1.07mm
材料	(Material):	DC01/St12
灭火级别	(Fire Class):	13A 70B C
包装尺寸	(Packing Size):	12 × 13 × 41cm



# EN3-7 手提式干粉灭火器

## Portable Dry Powder Fire Extinguisher



EN3-7 手提式干粉灭火器  
Portable Dry Powder Fire Extinguisher



型号	(Model):	MFZL2-2
外径	(Out-diameter):	Φ 110mm
容积	(Volume):	2.5L
瓶高	(Cylinder Length):	310mm
瓶重	(Cylinder Weight):	1.1Kg
灭火器重量	(Extinguisher Weight):	3.6Kg
灭火剂重量	(Dry Powder Filled Weight):	2Kg
温度范围	(Temperature Range):	-30℃~+60℃
最大工作压力	(Max. Working Pressure):	18bar
测试压力	(Test Pressure):	27bar
最小壁厚	(Min. Wall-thickness):	1.07mm
材料	(Material):	DC01/St12
灭火级别	(Fire Class):	13A 55B C
包装尺寸	(Packing Size):	12 × 13 × 41cm

# EN3-7 手提式干粉灭火器

## Portable Dry Powder Fire Extinguisher



EN3-7 手提式干粉灭火器  
Portable Dry Powder Fire Extinguisher



型号	(Model):	MFZL6-1
外径	(Out-diameter):	Φ 160mm
容积	(Volume):	7.9L
瓶高	(Cylinder Length):	450mm
瓶重	(Cylinder Weight):	2.8Kg
灭火器重量	(Extinguisher Weight):	9.5Kg
灭火剂重量	(Dry Powder Filled Weight):	6Kg
温度范围	(Temperature Range):	-30℃~+60℃
最大工作压力	(Max. Working Pressure):	18bar
测试压力	(Test Pressure):	27bar
最小壁厚	(Min. Wall-thickness):	1.24mm
材料	(Material):	DC01/St12
灭火级别	(Fire Class):	55A 233B C
包装尺寸	(Packing Size):	17 × 17 × 56cm



型号	(Model):	MFZL6
外径	(Out-diameter):	Φ 160mm
容积	(Volume):	7.9L
瓶高	(Cylinder Length):	450mm
瓶重	(Cylinder Weight):	2.8Kg
灭火器重量	(Extinguisher Weight):	9.5Kg
灭火剂重量	(Dry Powder Filled Weight):	6Kg
温度范围	(Temperature Range):	-30℃~+60℃
最大工作压力	(Max. Working Pressure):	18bar
测试压力	(Test Pressure):	27bar
最小壁厚	(Min. Wall-thickness):	1.24mm
材料	(Material):	DC01/St12
灭火级别	(Fire Class):	27A 183B C
包装尺寸	(Packing Size):	17 × 17 × 56cm

型号	(Model):	MFZL6-3
外径	(Out-diameter):	Φ 160mm
容积	(Volume):	7.9L
瓶高	(Cylinder Length):	450mm
瓶重	(Cylinder Weight):	2.8Kg
灭火器重量	(Extinguisher Weight):	9.5Kg
灭火剂重量	(Dry Powder Filled Weight):	6Kg
温度范围	(Temperature Range):	-30℃~+60℃
最大工作压力	(Max. Working Pressure):	18bar
测试压力	(Test Pressure):	27bar
最小壁厚	(Min. Wall-thickness):	1.24mm
材料	(Material):	DC01/St12
灭火级别	(Fire Class):	34A 183B C
包装尺寸	(Packing Size):	17 × 17 × 56cm





# EN3-7 手提式干粉灭火器

## Portable Dry Powder Fire Extinguisher



EN3-7 手提式干粉灭火器  
Portable Dry Powder Fire Extinguisher

型号	(Model):	MFZL9
外径	(Out-diameter):	Φ 180mm
容积	(Volume):	11.4L
瓶高	(Cylinder Length):	510mm
瓶重	(Cylinder Weight):	4.3Kg
灭火器重量	(Extinguisher Weight):	14Kg
灭火剂重量	(Dry Powder Filled Weight):	9Kg
温度范围	(Temperature Range):	-30℃~+60℃
最大工作压力	(Max. Working Pressure):	18bar
测试压力	(Test Pressure):	27bar
最小壁厚	(Min. Wall-thickness):	1.30mm
材料	(Material):	DC01/St12
灭火级别	(Fire Class):	34A 233B C
包装尺寸	(Packing Size):	19 × 19 × 64cm



型号	(Model):	MFZL9-1
外径	(Out-diameter):	Φ 180mm
容积	(Volume):	11.4L
瓶高	(Cylinder Length):	510mm
瓶重	(Cylinder Weight):	4.3Kg
灭火器重量	(Extinguisher Weight):	14Kg
灭火剂重量	(Dry Powder Filled Weight):	9Kg
温度范围	(Temperature Range):	-30℃~+60℃
最大工作压力	(Max. Working Pressure):	18bar
测试压力	(Test Pressure):	27bar
最小壁厚	(Min. Wall-thickness):	1.30mm
材料	(Material):	DC01/St12
灭火级别	(Fire Class):	43A 233B C
包装尺寸	(Packing Size):	19 × 19 × 64cm

# EN3-7 手提式干粉灭火器

## Portable Dry Powder Fire Extinguisher



EN3-7 手提式干粉灭火器  
Portable Dry Powder Fire Extinguisher

型号	(Model):	MFZL12
外径	(Out-diameter):	Φ 180mm
容积	(Volume):	13.6L
瓶高	(Cylinder Length):	600mm
瓶重	(Cylinder Weight):	5.0Kg
灭火器重量	(Extinguisher Weight):	18Kg
灭火剂重量	(Dry Powder Filled Weight):	12Kg
温度范围	(Temperature Range):	-30℃~+60℃
最大工作压力	(Max. Working Pressure):	18bar
测试压力	(Test Pressure):	27bar
最小壁厚	(Min. Wall-thickness):	1.30mm
材料	(Material):	DC01/St12
灭火级别	(Fire Class):	43A 233B C
包装尺寸	(Packing Size):	19 × 19 × 71cm



型号	(Model):	MFZL12-1
外径	(Out-diameter):	Φ 180mm
容积	(Volume):	13.6L
瓶高	(Cylinder Length):	600mm
瓶重	(Cylinder Weight):	5.0Kg
灭火器重量	(Extinguisher Weight):	18Kg
灭火剂重量	(Dry Powder Filled Weight):	12Kg
温度范围	(Temperature Range):	-30℃~+60℃
最大工作压力	(Max. Working Pressure):	18bar
测试压力	(Test Pressure):	27bar
最小壁厚	(Min. Wall-thickness):	1.30mm
材料	(Material):	DC01/St12
灭火级别	(Fire Class):	55A 233B C
包装尺寸	(Packing Size):	19 × 19 × 71cm





# EN3-7 手提式干粉灭火器(内置式)

Portable Dry Powder Fire Extinguisher(With Internal Cartridge)



## EN3-7 手提式干粉灭火器(内置式)

Portable Dry Powder Fire Extinguisher(With Internal Cartridge)



型号	(Model):	MFZL6-2
外径	(Out-diameter):	Φ 160mm
容积	(Volume):	7.2L
瓶高	(Cylinder Length):	415mm
瓶重	(Cylinder Weight):	2.5Kg
灭火器重量	(Extinguisher Weight):	10.6Kg
灭火剂重量	(Dry Powder Filled Weight):	6Kg
温度范围	(Temperature Range):	-30℃~+60℃
最大工作压力	(Max. Working Pressure):	18bar
测试压力	(Test Pressure):	27bar
最小壁厚	(Min. Wall-thickness):	1.24mm
材料	(Material):	DC01/St12
灭火级别	(Fire Class):	27A 183B C
包装尺寸	(Packing Size):	17 × 17 × 54cm
<b>内置小钢瓶 (Internal Gas Cartridge)</b>		
驱动气体	(Drive Gas):	CO <sub>2</sub> (150g)
材料	(Material):	St52



型号	(Model):	MFZL6-4
外径	(Out-diameter):	Φ 160mm
容积	(Volume):	7.2L
瓶高	(Cylinder Length):	415mm
瓶重	(Cylinder Weight):	2.5Kg
灭火器重量	(Extinguisher Weight):	10.6Kg
灭火剂重量	(Dry Powder Filled Weight):	6Kg
温度范围	(Temperature Range):	-30℃~+60℃
最大工作压力	(Max. Working Pressure):	18bar
测试压力	(Test Pressure):	27bar
最小壁厚	(Min. Wall-thickness):	1.24mm
材料	(Material):	DC01/St12
灭火级别	(Fire Class):	34A 183B C
包装尺寸	(Packing Size):	17 × 17 × 54cm
<b>内置小钢瓶 (Internal Gas Cartridge)</b>		
驱动气体	(Drive Gas):	CO <sub>2</sub> (150g)
材料	(Material):	St52



# EN3-7 手提式干粉灭火器(内置式)

Portable Dry Powder Fire Extinguisher(With Internal Cartridge)



## EN3-7 手提式干粉灭火器(内置式)

Portable Dry Powder Fire Extinguisher(With Internal Cartridge)



型号	(Model):	MFZL9-2
外径	(Out-diameter):	Φ 180mm
容积	(Volume):	10.5L
瓶高	(Cylinder Length):	475mm
瓶重	(Cylinder Weight):	4.1Kg
灭火器重量	(Extinguisher Weight):	15.5Kg
灭火剂重量	(Dry Powder Filled Weight):	9Kg
温度范围	(Temperature Range):	-30℃~+60℃
最大工作压力	(Max. Working Pressure):	18bar
测试压力	(Test Pressure):	27bar
最小壁厚	(Min. Wall-thickness):	1.30mm
材料	(Material):	DC01/St12
灭火级别	(Fire Class):	43A 183B C
包装尺寸	(Packing Size):	19 × 19 × 61cm
<b>内置小钢瓶 (Internal Gas Cartridge)</b>		
驱动气体	(Drive Gas):	CO <sub>2</sub> (180g)
材料	(Material):	St52

型号	(Model):	MFZL12-2
外径	(Out-diameter):	Φ 180mm
容积	(Volume):	13.6L
瓶高	(Cylinder Length):	600mm
瓶重	(Cylinder Weight):	5Kg
灭火器重量	(Extinguisher Weight):	19Kg
灭火剂重量	(Dry Powder Filled Weight):	12Kg
温度范围	(Temperature Range):	-30℃~+60℃
最大工作压力	(Max. Working Pressure):	18bar
测试压力	(Test Pressure):	27bar
最小壁厚	(Min. Wall-thickness):	1.30mm
材料	(Material):	DC01/St12
灭火级别	(Fire Class):	55A 233B C
包装尺寸	(Packing Size):	19 × 19 × 72cm
<b>内置小钢瓶 (Internal Gas Cartridge)</b>		
驱动气体	(Drive Gas):	CO <sub>2</sub> (225g)
材料	(Material):	St52







# EN3-7 手提式泡沫灭火器

Portable Foam Fire Extinguisher



## EN3-7 手提式泡沫灭火器

Portable Foam Fire Extinguisher



型号	(Model):	MJPZ2
外径	(Out-diameter):	Φ 110mm
容积	(Volume):	2.3L
瓶高	(Cylinder Length):	310mm
瓶重	(Cylinder Weight):	1.4Kg
灭火器重量	(Extinguisher Weight):	4Kg
灭火剂重量	(Dry Powder Filled Weight):	2L
温度范围	(Temperature Range):	+5°C~+60°C
最大工作压力	(Max. Working Pressure):	18bar
测试压力	(Test Pressure):	27bar
最小壁厚	(Min. Wall-thickness):	1.07mm
材料	(Material):	DC01/St12
灭火级别	(Fire Class):	5A 34B
包装尺寸	(Packing Size):	13 × 13 × 41cm



型号	(Model):	MJPZ2-1
外径	(Out-diameter):	Φ 110mm
容积	(Volume):	2.3L
瓶高	(Cylinder Length):	310mm
瓶重	(Cylinder Weight):	1.4Kg
灭火器重量	(Extinguisher Weight):	3.9Kg
灭火剂重量	(Dry Powder Filled Weight):	2L
温度范围	(Temperature Range):	+5°C~+60°C
最大工作压力	(Max. Working Pressure):	18bar
测试压力	(Test Pressure):	27bar
最小壁厚	(Min. Wall-thickness):	1.07mm
材料	(Material):	DC01/St12
灭火级别	(Fire Class):	5A 55B
包装尺寸	(Packing Size):	13 × 13 × 41cm



# EN3-7 手提式泡沫灭火器

Portable Foam Fire Extinguisher



## EN3-7 手提式泡沫灭火器

Portable Foam Fire Extinguisher



型号	(Model):	MJPZ6
外径	(Out-diameter):	Φ 160mm
容积	(Volume):	7.9L
瓶高	(Cylinder Length):	470mm
瓶重	(Cylinder Weight):	3.3Kg
灭火器重量	(Extinguisher Weight):	10Kg
灭火剂重量	(Dry Powder Filled Weight):	6L
温度范围	(Temperature Range):	+5°C~+60°C
最大工作压力	(Max. Working Pressure):	18bar
测试压力	(Test Pressure):	27bar
最小壁厚	(Min. Wall-thickness):	1.24mm
材料	(Material):	DC01/St12
灭火级别	(Fire Class):	13A 113B
包装尺寸	(Packing Size):	17 × 17 × 58cm



型号	(Model):	MJPZ6-1
外径	(Out-diameter):	Φ 160mm
容积	(Volume):	7.9L
瓶高	(Cylinder Length):	470mm
瓶重	(Cylinder Weight):	3.3Kg
灭火器重量	(Extinguisher Weight):	10Kg
灭火剂重量	(Dry Powder Filled Weight):	6L
温度范围	(Temperature Range):	+5°C~+60°C
最大工作压力	(Max. Working Pressure):	18bar
测试压力	(Test Pressure):	27bar
最小壁厚	(Min. Wall-thickness):	1.24mm
材料	(Material):	DC01/St12
灭火级别	(Fire Class):	13A 144B
包装尺寸	(Packing Size):	17 × 17 × 58cm



# EN3-7 手提式泡沫灭火器

## Portable Foam Fire Extinguisher



EN3-7 手提式泡沫灭火器  
Portable Foam Fire Extinguisher

型号	(Model):	MJPZ9
外径	(Out-diameter):	Φ 180mm
容积	(Volume):	11.2L
瓶高	(Cylinder Length):	525mm
瓶重	(Cylinder Weight):	4.6Kg
灭火器重量	(Extinguisher Weight):	14.5Kg
灭火剂重量	(Dry Powder Filled Weight):	9L
温度范围	(Temperature Range):	+5℃~+60℃
最大工作压力	(Max. Working Pressure):	18bar
测试压力	(Test Pressure):	27bar
最小壁厚	(Min. Wall-thickness):	1.30mm
材料	(Material):	DC01/St12
灭火级别	(Fire Class):	13A 183B
包装尺寸	(Packing Size):	19 × 19 × 64cm



型号	(Model):	MJPZ9-1
外径	(Out-diameter):	Φ 180mm
容积	(Volume):	11.2L
瓶高	(Cylinder Length):	525mm
瓶重	(Cylinder Weight):	4.6Kg
灭火器重量	(Extinguisher Weight):	14.5Kg
灭火剂重量	(Dry Powder Filled Weight):	9L
温度范围	(Temperature Range):	+5℃~+60℃
最大工作压力	(Max. Working Pressure):	18bar
测试压力	(Test Pressure):	27bar
最小壁厚	(Min. Wall-thickness):	1.30mm
材料	(Material):	DC01/St12
灭火级别	(Fire Class):	13A 183B
包装尺寸	(Packing Size):	19 × 19 × 64cm

# EN3-7 手提式泡沫灭火器(内置式)

## Portable Foam Fire Extinguisher(With Internal Gas Cartridge)



EN3-7 手提式泡沫灭火器(内置式)  
Portable Foam Fire Extinguisher(With Internal Cartridge)

型号	(Model):	MJPZ6-3
外径	(Out-diameter):	Φ 160mm
容积	(Volume):	7.9L
瓶高	(Cylinder Length):	470mm
瓶重	(Cylinder Weight):	3.3Kg
灭火器重量	(Extinguisher Weight):	11Kg
灭火剂重量	(Dry Powder Filled Weight):	6L
温度范围	(Temperature Range):	+5℃~+60℃
最大工作压力	(Max. Working Pressure):	18bar
测试压力	(Test Pressure):	27bar
最小壁厚	(Min. Wall-thickness):	1.24mm
材料	(Material):	DC01/St12
灭火级别	(Fire Class):	13A 113B C
包装尺寸	(Packing Size):	17 × 17 × 59cm

内置小钢瓶	(Internal Gas Cartridge)	
驱动气体	(Drive Gas):	CO <sub>2</sub> (55g)
材料	(Material):	St52



型号	(Model):	MJPZ9-3
外径	(Out-diameter):	Φ 180mm
容积	(Volume):	11.2L
瓶高	(Cylinder Length):	530mm
瓶重	(Cylinder Weight):	4.6Kg
灭火器重量	(Extinguisher Weight):	16Kg
灭火剂重量	(Dry Powder Filled Weight):	9L
温度范围	(Temperature Range):	+5℃~+60℃
最大工作压力	(Max. Working Pressure):	18bar
测试压力	(Test Pressure):	27bar
最小壁厚	(Min. Wall-thickness):	1.30mm
材料	(Material):	DC01/St12
灭火级别	(Fire Class):	21A 183B C
包装尺寸	(Packing Size):	19 × 19 × 65cm

内置小钢瓶	(Internal Gas Cartridge)	
驱动气体	(Drive Gas):	CO <sub>2</sub> (60g)
材料	(Material):	St52





# EN3-7 手提式清水灭火器

## Portable Water Fire Extinguisher



EN3-7 手提式清水灭火器  
Portable Water Fire Extinguisher

型号	(Model):	MSQ9
外径	(Out-diameter):	Φ 180mm
容积	(Volume):	11.2L
瓶高	(Cylinder Length):	525mm
瓶重	(Cylinder Weight):	4.6Kg
灭火器重量	(Extinguisher Weight):	14.5Kg
灭火剂重量	(Dry Powder Filled Weight):	9L
温度范围	(Temperature Range):	+5℃~+60℃
最大工作压力	(Max. Working Pressure):	18bar
测试压力	(Test Pressure):	27bar
最小壁厚	(Min. Wall-thickness):	1.30mm
材料	(Material):	DC01/St12
灭火级别	(Fire Class):	13A
包装尺寸	(Packing Size):	19 × 19 × 64cm



型号	(Model):	MSQ9-1
外径	(Out-diameter):	Φ 180mm
容积	(Volume):	11.2L
瓶高	(Cylinder Length):	525mm
瓶重	(Cylinder Weight):	4.6Kg
灭火器重量	(Extinguisher Weight):	14.5Kg
灭火剂重量	(Dry Powder Filled Weight):	9L
温度范围	(Temperature Range):	+5℃~+60℃
最大工作压力	(Max. Working Pressure):	18bar
测试压力	(Test Pressure):	27bar
最小壁厚	(Min. Wall-thickness):	1.30mm
材料	(Material):	DC01/St12
灭火级别	(Fire Class):	13A
包装尺寸	(Packing Size):	19 × 19 × 64cm

# EN3-7 手提式CO2灭火器

## Portable CO2 Fire Extinguisher



EN3-7 手提式CO2灭火器(铝合金)  
Portable CO2 Fire Extinguisher (Aluminium-alloy)

型号	(Model):	WN/ML2
外径	(Out-diameter):	Φ 111mm
容积	(Volume):	3L
瓶高	(Cylinder Length):	475mm
瓶重	(Cylinder Weight):	3.2Kg
灭火器重量	(Extinguisher Weight):	6Kg
灭火剂重量	(Dry Powder Filled Weight):	2Kg
温度范围	(Temperature Range):	-30℃~+60℃
最大工作压力	(Max. Working Pressure):	174bar
测试压力	(Test Pressure):	250bar
最小壁厚	(Min. Wall-thickness):	6.32mm
材料	(Material):	AA6061
灭火级别	(Fire Class):	34B
包装尺寸	(Packing Size):	16 × 13 × 59.5cm



型号	(Model):	WN/ML5
外径	(Out-diameter):	Φ 159mm
容积	(Volume):	7.5L
瓶高	(Cylinder Length):	580mm
瓶重	(Cylinder Weight):	8Kg
灭火器重量	(Extinguisher Weight):	14Kg
灭火剂重量	(Dry Powder Filled Weight):	5Kg
温度范围	(Temperature Range):	-30℃~+60℃
最大工作压力	(Max. Working Pressure):	174bar
测试压力	(Test Pressure):	250bar
最小壁厚	(Min. Wall-thickness):	9.05mm
材料	(Material):	AA6061
灭火级别	(Fire Class):	89B
包装尺寸	(Packing Size):	22 × 17 × 70cm





# EN3-7 手提式CO2灭火器

## Portable CO2 Fire Extinguisher



**EN3-7 手提式CO2灭火器(铝合金)**  
Portable CO2 Fire Extinguisher (Aluminium-alloy)



型号	(Model):	WN215/ML2
外径	(Out-diameter):	Φ 111mm
容积	(Volume):	3L
瓶高	(Cylinder Length):	445mm
瓶重	(Cylinder Weight):	2.3Kg
灭火器重量	(Extinguisher Weight):	5Kg
灭火剂重量	(Dry Powder Filled Weight):	2Kg
温度范围	(Temperature Range):	-30℃~+60℃
最大工作压力	(Max. Working Pressure):	169.3bar
测试压力	(Test Pressure):	215bar
最小壁厚	(Min. Wall-thickness):	4.4mm
材料	(Material):	AA6061
灭火级别	(Fire Class):	34B
包装尺寸	(Packing Size):	16 × 13 × 56.5cm

# EN3-7 手提式CO2灭火器

## Portable CO2 Fire Extinguisher



**EN3-7 手提式CO2灭火器(合金钢)**  
Portable CO2 Fire Extinguisher(alloy-steel)



型号	(Model):	WN/M2
外径	(Out-diameter):	Φ 105mm
容积	(Volume):	3L
瓶高	(Cylinder Length):	475mm
瓶重	(Cylinder Weight):	4.2Kg
灭火器重量	(Extinguisher Weight):	7Kg
灭火剂重量	(Dry Powder Filled Weight):	2Kg
温度范围	(Temperature Range):	-30℃~+60℃
最大工作压力	(Max. Working Pressure):	174bar
测试压力	(Test Pressure):	250bar
最小壁厚	(Min. Wall-thickness):	2.3mm
材料	(Material):	34CrMo4
灭火级别	(Fire Class):	34B
包装尺寸	(Packing Size):	16 × 13 × 60cm



型号	(Model):	WN215/ML5
外径	(Out-diameter):	Φ 152mm
容积	(Volume):	7.5L
瓶高	(Cylinder Length):	575mm
瓶重	(Cylinder Weight):	5.5Kg
灭火器重量	(Extinguisher Weight):	11Kg
灭火剂重量	(Dry Powder Filled Weight):	5Kg
温度范围	(Temperature Range):	-30℃~+60℃
最大工作压力	(Max. Working Pressure):	169.3bar
测试压力	(Test Pressure):	215bar
最小壁厚	(Min. Wall-thickness):	6.02mm
材料	(Material):	AA6061
灭火级别	(Fire Class):	89B
包装尺寸	(Packing Size):	21 × 17 × 69.5cm

型号	(Model):	WN/M5
外径	(Out-diameter):	Φ 138mm
容积	(Volume):	7.5L
瓶高	(Cylinder Length):	655mm
瓶重	(Cylinder Weight):	8.5Kg
灭火器重量	(Extinguisher Weight):	14Kg
灭火剂重量	(Dry Powder Filled Weight):	5Kg
温度范围	(Temperature Range):	-30℃~+60℃
最大工作压力	(Max. Working Pressure):	174bar
测试压力	(Test Pressure):	250bar
最小壁厚	(Min. Wall-thickness):	3.0mm
材料	(Material):	34CrMo4
灭火级别	(Fire Class):	89B
包装尺寸	(Packing Size):	21 × 15 × 78cm





# EN1866-1 推车式灭火器

Mobile Fire Extinguisher



**EN1866-1 推车式干粉灭火器**  
Mobile Dry Powder Fire Extinguisher



型号	(Model):	WN/MFTZ25
外径	(Out-diameter):	Φ270mm
容积	(Volume):	30.5L
瓶高	(Cylinder Length):	626mm
瓶重	(Cylinder Weight):	13.2Kg
灭火器重量	(Extinguisher Weight):	59Kg
灭火剂重量	(Dry Powder Filled Weight):	25Kg
温度范围	(Temperature Range):	-30℃~+60℃
最大工作压力	(Max. Working Pressure):	18bar
测试压力	(Test Pressure):	35bar
最小壁厚	(Min. Wall-thickness):	2.1mm
材料	(Material):	HP295
灭火级别	(Fire Class):	55A   B C
包装尺寸	(Packing Size):	58 × 45 × 98cm

# EN1866-1 推车式灭火器

Mobile Fire Extinguisher



**EN1866-1 推车式泡沫灭火器**  
Mobile Foam Fire Extinguisher



型号	(Model):	WN/MPTZ25
外径	(Out-diameter):	Φ270mm
容积	(Volume):	29.5L
瓶高	(Cylinder Length):	626mm
瓶重	(Cylinder Weight):	14.2Kg
灭火器重量	(Extinguisher Weight):	60Kg
灭火剂重量	(Dry Powder Filled Weight):	25L
温度范围	(Temperature Range):	+5℃~+60℃
最大工作压力	(Max. Working Pressure):	18bar
测试压力	(Test Pressure):	35bar
最小壁厚	(Min. Wall-thickness):	2.1mm
材料	(Material):	HP295
灭火级别	(Fire Class):	55A   B
包装尺寸	(Packing Size):	58 × 45 × 98cm



型号	(Model):	WN/MFTZ50
外径	(Out-diameter):	Φ320mm
容积	(Volume):	60.5L
瓶高	(Cylinder Length):	875mm
瓶重	(Cylinder Weight):	21.2Kg
灭火器重量	(Extinguisher Weight):	95Kg
灭火剂重量	(Dry Powder Filled Weight):	50Kg
温度范围	(Temperature Range):	-30℃~+60℃
最大工作压力	(Max. Working Pressure):	18bar
测试压力	(Test Pressure):	35bar
最小壁厚	(Min. Wall-thickness):	2.4mm
材料	(Material):	HP295
灭火级别	(Fire Class):	55A    B C
包装尺寸	(Packing Size):	64 × 49 × 110cm

型号	(Model):	WN/MPTZ50
外径	(Out-diameter):	Φ320mm
容积	(Volume):	59L
瓶高	(Cylinder Length):	875mm
瓶重	(Cylinder Weight):	22.2Kg
灭火器重量	(Extinguisher Weight):	96Kg
灭火剂重量	(Dry Powder Filled Weight):	50L
温度范围	(Temperature Range):	+5℃~+60℃
最大工作压力	(Max. Working Pressure):	18bar
测试压力	(Test Pressure):	35bar
最小壁厚	(Min. Wall-thickness):	2.4mm
材料	(Material):	HP295
灭火级别	(Fire Class):	55A    B C
包装尺寸	(Packing Size):	64 × 49 × 110cm





# EN1866-1 推车式灭火器

## Mobile Fire Extinguisher



**EN1866-1 推车式CO2灭火器(合金钢)**  
Mobile CO2 Fire Extinguisher (alloy-steel)

型号	(Model):	WN/MTT10(5 × 2)
外径	(Out-diameter):	Φ 135.6mm
容积	(Volume):	15(7.5 × 2)L
瓶高	(Cylinder Length):	650mm
瓶重	(Cylinder Weight):	7.6kg
灭火器重量	(Extinguisher Weight):	48Kg
灭火剂重量	(Dry Powder Filled Weight):	10Kg
温度范围	(Temperature Range):	-30℃~+60℃
最大工作压力	(Max. Working Pressure):	174bar
测试压力	(Test Pressure):	250bar
最小壁厚	(Min. Wall-thickness):	2.59mm
材料	(Material):	34CrMo4
灭火级别	(Fire Class):	89B
包装尺寸	(Packing Size):	30 × 46 × 85cm



型号	(Model):	WN/MTT10
外径	(Out-diameter):	Φ 156mm
容积	(Volume):	15L
瓶高	(Cylinder Length):	980mm
瓶重	(Cylinder Weight):	15.8kg
灭火器重量	(Extinguisher Weight):	42Kg
灭火剂重量	(Dry Powder Filled Weight):	10Kg
温度范围	(Temperature Range):	-30℃~+60℃
最大工作压力	(Max. Working Pressure):	174bar
测试压力	(Test Pressure):	250bar
最小壁厚	(Min. Wall-thickness):	3.0mm
材料	(Material):	34CrMo4
灭火级别	(Fire Class):	113B
包装尺寸	(Packing Size):	46 × 30 × 120cm

# EN1866-1 推车式灭火器

## Mobile Fire Extinguisher



**EN1866-1 推车式CO2灭火器(合金钢)**  
Mobile CO2 Fire Extinguisher (alloy-steel)

型号	(Model):	WN/MTT30
外径	(Out-diameter):	Φ 229mm
容积	(Volume):	43L
瓶高	(Cylinder Length):	1280mm
瓶重	(Cylinder Weight):	48kg
灭火器重量	(Extinguisher Weight):	104Kg
灭火剂重量	(Dry Powder Filled Weight):	30Kg
温度范围	(Temperature Range):	-30℃~+60℃
最大工作压力	(Max. Working Pressure):	200bar
测试压力	(Test Pressure):	300bar
最小壁厚	(Min. Wall-thickness):	5.2mm
材料	(Material):	34CrMo4
灭火级别	(Fire Class):	144B
包装尺寸	(Packing Size):	118 × 55 × 124cm



**UL299 手提式干粉灭火器**  
Portable Dry Chemical Fire Extinguisher



**UL299 手提式干粉灭火器**  
Portable Dry Chemical Fire Extinguisher

型号	(Model):	DC-UL2.5
外径	(Out-diameter):	Φ 79.4mm
容积	(Volume):	1.38L
瓶高	(Cylinder Length):	332mm
瓶重	(Cylinder Weight):	0.79Kg
灭火器重量	(Extinguisher Weight):	2.2Kg
灭火剂重量	(Dry Powder Filled Weight):	1.13Kg(2.5Lbs)
温度范围	(Temperature Range):	-40℃~+49℃
最大工作压力	(Max. Working Pressure):	13.5bar(195psi)
测试压力	(Test Pressure):	40.5bar(585psi)
最小壁厚	(Min. Wall-thickness):	0.87mm
材料	(Material):	DC01
灭火级别	(Fire Class):	1-A:10-B:C
包装尺寸	(Packing Size):	9 × 9 × 40cm

**UL299 手提式干粉灭火器**  
Portable Dry Chemical Fire Extinguisher



**UL299 手提式干粉灭火器**  
Portable Dry Chemical Fire Extinguisher

型号	(Model):	DC-UL10
外径	(Out-diameter):	Φ 129mm
容积	(Volume):	5.05L
瓶高	(Cylinder Length):	450mm
瓶重	(Cylinder Weight):	2.68Kg
灭火器重量	(Extinguisher Weight):	8.1Kg
灭火剂重量	(Dry Powder Filled Weight):	4.5Kg(10Lbs)
温度范围	(Temperature Range):	-40℃~+49℃
最大工作压力	(Max. Working Pressure):	13.5bar(195psi)
测试压力	(Test Pressure):	40.5bar(585psi)
最小壁厚	(Min. Wall-thickness):	1.20mm
材料	(Material):	DC01
灭火级别	(Fire Class):	4-A:60-B:C
包装尺寸	(Packing Size):	14 × 15 × 53cm



型号	(Model):	DC-UL5
外径	(Out-diameter):	Φ 108mm
容积	(Volume):	2.70L
瓶高	(Cylinder Length):	350mm
瓶重	(Cylinder Weight):	1.45Kg
灭火器重量	(Extinguisher Weight):	4.5Kg
灭火剂重量	(Dry Powder Filled Weight):	2.3Kg(5Lbs)
温度范围	(Temperature Range):	-40℃~+49℃
最大工作压力	(Max. Working Pressure):	13.5bar(195psi)
测试压力	(Test Pressure):	40.5bar(585psi)
最小壁厚	(Min. Wall-thickness):	1.07mm
材料	(Material):	DC01
灭火级别	(Fire Class):	2-A:30-B:C
包装尺寸	(Packing Size):	12 × 13 × 43cm

型号	(Model):	DC-UL20
外径	(Out-diameter):	Φ 180mm
容积	(Volume):	11.01L
瓶高	(Cylinder Length):	505mm
瓶重	(Cylinder Weight):	5.02Kg
灭火器重量	(Extinguisher Weight):	14.7Kg
灭火剂重量	(Dry Powder Filled Weight):	9.0Kg(20Lbs)
温度范围	(Temperature Range):	-40℃~+49℃
最大工作压力	(Max. Working Pressure):	13.5bar(195psi)
测试压力	(Test Pressure):	40.5bar(585psi)
最小壁厚	(Min. Wall-thickness):	1.40mm
材料	(Material):	DC01
灭火级别	(Fire Class):	10-A:80-B:C
包装尺寸	(Packing Size):	19 × 19 × 59cm







手提式干粉灭火器  
Portable Dry Powder Fire Extinguisher



规格	外径	容积	瓶高	瓶重	灭火器重量	灭火剂重量	温度范围	最大工作压力	测试压力	最小壁厚	材料	灭火级别	包装尺寸
Spec.	Out-diameter	Volume	Cylinder Length	Cylinder Weight	Extinguisher Weight	Filling Weight	Temperature Range	Max.Working Pressure	Test Pressure	Min.Wall-thickness	Material	Fire Class	Packing Size
1Kg	Φ85mm	1.25L	270mm	0.7Kg	2.1Kg	1Kg	-30℃~+60℃	18bar	27bar	1.0mm	DC01/St12	8A 34B C	10×10×36cm
2Kg	Φ110mm	2.5L	310mm	1.1Kg	3.6Kg	2Kg				1.07mm		13A 55B C	13×13×41cm
3Kg	Φ130mm	3.8L	335mm	1.6Kg	5.0Kg	3Kg				1.14mm		13A 70B C	14×15×44cm
4Kg	Φ130mm	5.0L	430mm	2.3Kg	6.7Kg	4Kg				1.14mm		21A 113B C	14×15×54cm
4Kg	Φ140mm	5.4L	400mm	2.1Kg	6.5Kg	4Kg				1.17mm		21A 113B C	15×15×51cm
5Kg	Φ160mm	6.8L	390mm	2.5Kg	8.0Kg	5Kg				1.24mm		21A 144B C	17×17×50cm
6Kg	Φ160mm	7.9L	450mm	2.8Kg	9.3Kg	6Kg				1.24mm		27A 183B C	17×17×56cm
8Kg	Φ180mm	9.9L	445mm	3.7Kg	12.0Kg	8Kg				1.30mm		34A 183B C	19×19×56cm
9Kg	Φ180mm	11.4L	510mm	4.3Kg	13.8Kg	9Kg				1.30mm		34A 233B C	19×19×62cm
10Kg	Φ180mm	12.3L	545mm	4.6Kg	15.5Kg	10Kg				1.30mm		43A 233B C	19×19×66cm
12Kg	Φ180mm	13.6L	600mm	5.0Kg	18.0Kg	12Kg				1.30mm		55A 233B C	19×19×71cm

手提式干粉灭火器(车用)

Portable Dry Powder Fire Extinguisher( Car-used )



规格	外径	容积	瓶高	瓶重	灭火器重量	灭火剂重量	温度范围	最大工作压力	测试压力	最小壁厚	材料	灭火级别	包装尺寸
Spec.	Out-diameter	Volume	Cylinder Length	Cylinder Weight	Extinguisher Weight	Filling Weight	Temperature Range	Max.Working Pressure	Test Pressure	Min.Wall-thickness	Material	Fire Class	Packing Size
1Kg	Φ89.5mm	1.1L	220mm	0.33Kg	1.6Kg	1Kg	-30℃~+60℃	18.5bar	26.5bar	1.12mm	1050	5A 34B C	11×11×30cm
2Kg	Φ108mm	2.3L	320mm	0.71Kg	3Kg	2Kg	-30℃~+60℃	19.5bar	28bar	1.10mm	1050	13A 55B C	13×13×40cm
2Kg	Φ110mm	2.3L	275mm	1.4Kg	3.6Kg	2Kg	-30℃~+60℃	18bar	27bar	1.07mm	DC01/St12	13A 55B C	13×13×41cm

手提式泡沫灭火器

Portable Foam Fire Extinguisher



规格	外径	容积	瓶高	瓶重	灭火器重量	灭火剂重量	温度范围	最大工作压力	测试压力	最小壁厚	材料	灭火级别	包装尺寸
Spec.	Out-diameter	Volume	Cylinder Length	Cylinder Weight	Extinguisher Weight	Filling Weight	Temperature Range	Max.Working Pressure	Test Pressure	Min.Wall-thickness	Material	Fire Class	Packing Size
2L	Φ110mm	2.4L	310mm	1.4Kg	4.0Kg	2L	+5℃~+60℃	18bar	27bar	1.07mm	DC01/St12	5A 34B	13×13×41cm
4L	Φ130mm	4.8L	430mm	2.3Kg	4.0Kg	4L				1.14mm		8A 70B C	14×15×54cm
6L	Φ160mm	7.9L	470mm	3.3Kg	10Kg	6L				1.24mm		13A 113B C	17×17×56cm
9L	Φ180mm	11.2L	525mm	4.6Kg	14.5Kg	9L				1.30mm		13A 183B C	19×19×64cm





# CE 手提式灭火器 (内置式)

Portable Fire Extinguisher(With Internal Gas Cartridge)



# CE 手提式灭火器 (内置式)

Portable Fire Extinguisher(With Internal Gas Cartridge)



## 手提式干粉灭火器(内置式)

Portable Dry Powder Fire Extinguisher(With Internal Gas Cartridge)



规格 Spec.	外径 Out-diameter	容积 Volume	瓶高 Cylinder Length	瓶重 Cylinder Weight	灭火器重量 Extinguisher Weight	灭火剂重量 Filling Weight	温度范围 Temperature Range	最大工作压力 Max. Working Pressure	测试压力 Test Pressure	最小壁厚 Min. Wall-thickness	材料 Material	灭火级别 Fire Class	包装尺寸 Packing Size	内置小钢瓶 Internal Gas Cartridge	
														驱动气体 Drive gas	材料 Material
4Kg	Φ 140mm	5.3L	400mm	2.2Kg	8.0Kg	4Kg	-30℃~ +60℃	18bar	27bar	1.17 mm	DC01 /St12	21A 113B C	15 × 15 × 52cm	CO2(75g)	St52
6Kg	Φ 160mm	7.9L	455mm	2.9Kg	11.0Kg	6Kg						27A 183B C	17 × 17 × 57cm	CO2(120g)	St52
9Kg	Φ 180mm	11.4L	515mm	4.4Kg	15.0Kg	9Kg						34A 233B C	19 × 19 × 64cm	CO2(180g)	St52
12Kg	Φ 180mm	13.6L	605mm	5.0Kg	18.5Kg	12Kg						55A 233B C	19 × 19 × 73cm	CO2(225g)	St52

## 手提式泡沫灭火器(内置式)

Portable Foam Fire Extinguisher(With Internal Gas Cartridge)



规格 Spec.	外径 Out-diameter	容积 Volume	瓶高 Cylinder Length	瓶重 Cylinder Weight	灭火器重量 Extinguisher Weight	灭火剂重量 Filling Weight	温度范围 Temperature Range	最大工作压力 Max. Working Pressure	测试压力 Test Pressure	最小壁厚 Min. Wall-thickness	材料 Material	灭火级别 Fire Class	包装尺寸 Packing Size	内置小钢瓶 Internal Gas Cartridge	
														驱动气体 Drive gas	材料 Material
6L	Φ 160mm	7.9L	470mm	3.3Kg	11.0Kg	6L	+5℃~ +60℃	18bar	27bar	1.24 mm	DC01 /St12	13A 113B	17 × 17 × 59cm	CO <sub>2</sub> (55g)	St52
9L	Φ 180mm	11.2L	530mm	4.6Kg	16.0Kg	9L						21A 183B	19 × 19 × 65cm	CO <sub>2</sub> (60g)	St52





# CE 手提式CO2灭火器 (铝合金)

## Portable CO2 Fire Extinguisher (Aluminium-alloy)



# CE 手提式CO2灭火器 (铝合金)

## Portable CO2 Fire Extinguisher (Aluminium-alloy)



### 手提式二氧化碳灭火器 (铝合金)

#### Portable CO2 Fire Extinguisher (Aluminium-alloy)



规格 Spec.	外径 Out-diameter	容积 Volume	瓶高 Cylinder Length	瓶重 Cylinder Weight	灭火器重量 Extinguisher Weight	灭火剂重量 Filling Weight	温度范围 Temperature Range	最大工作压力 Max. Working Pressure	测试压力 Test Pressure	最小壁厚 Min. Wall-thickness	材料 Material	灭火级别 Fire Class	包装尺寸 Packing Size
2Kg	Φ 111mm	3L	475mm	3.2Kg	6Kg	2Kg	-20℃~ +60℃	174bar	250bar	6.32mm	AA6061	34B	16 × 13 × 59.5cm
5Kg	Φ 159mm	7.5L	580mm	8Kg	14Kg	5Kg				9.05mm		89B	22 × 17 × 70cm
2Kg	Φ 111mm	2.67L	430mm	3Kg	6Kg	2Kg	-30℃~ +60℃	216bar	315bar	6.61mm		34B	16 × 13 × 55cm
5Kg	Φ 159mm	6.67L	535mm	8Kg	14Kg	5Kg				9.46mm		89B	22 × 17 × 65.5cm

### 手提式二氧化碳灭火器 (铝合金)

#### Portable CO2 Fire Extinguisher (Aluminium-alloy)



规格 Spec.	外径 Out-diameter	容积 Volume	瓶高 Cylinder Length	瓶重 Cylinder Weight	灭火器重量 Extinguisher Weight	灭火剂重量 Filling Weight	温度范围 Temperature Range	最大工作压力 Max. Working Pressure	测试压力 Test Pressure	最小壁厚 Min. Wall-thickness	材料 Material	灭火级别 Fire Class	包装尺寸 Packing Size
2Kg	Φ 111mm	3L	445mm	2.3Kg	5Kg	2Kg	-30℃~ +60℃	169.3bar	215bar	4.4mm	AA6061	34B	16 × 13 × 56.5cm
5Kg	Φ 152mm	7.5L	575mm	5.5Kg	12Kg	5Kg				6.02mm		89B	21 × 17 × 69.5cm



**CE 手提式CO2灭火器(合金钢)**  
Portable CO2 Fire Extinguisher(Alloy-steel)



**CE 手提式CO2灭火器(合金钢)**  
Portable CO2 Fire Extinguisher(Alloy-steel)



**手提式CO2灭火器(合金钢)**  
Portable CO2 Fire Extinguisher(Alloy-steel)



规格 Spec.	外径 Out-diameter	容积 Volume	瓶高 Cylinder Length	瓶重 Cylinder Weight	灭火器重量 Extinguisher Weight	灭火剂重量 Filling Weight	温度范围 Temperature Range	最大工作压力 Max.Working Pressure	测试压力 Test Pressure	最小壁厚 Min.Wall-thickness	材料 Material	灭火级别 Fire Class	包装尺寸 Packing Size
2Kg	φ 105mm	3L	475mm	4.9Kg	7Kg	2Kg	-20℃~ +60℃	174bar	250bar	2.3mm	34CrMo4	34B	16 × 13 × 60cm
3Kg	φ 138mm	4.5L	440mm	6.4Kg	11Kg	3Kg				3.0mm		34B	21 × 15 × 56cm
4.5Kg	φ 138mm	6.8L	600mm	8.0Kg	14Kg	4.5Kg				3.0mm		70B	21 × 15 × 73cm
5Kg	φ 138mm	7.5L	655mm	9.3Kg	15Kg	5Kg				3.0mm		89B	21 × 15 × 78cm

**手提式CO2灭火器(合金钢)**  
Portable CO2 Fire Extinguisher(Alloy-steel)



规格 Spec.	外径 Out-diameter	容积 Volume	瓶高 Cylinder Length	瓶重 Cylinder Weight	灭火器重量 Extinguisher Weight	灭火剂重量 Filling Weight	温度范围 Temperature Range	最大工作压力 Max.Working Pressure	测试压力 Test Pressure	最小壁厚 Min.Wall-thickness	材料 Material	灭火级别 Fire Class	包装尺寸 Packing Size
2Kg	φ 105mm	2.67L	440mm	4.3Kg	6.6Kg	2Kg	-30℃~ +60℃	216bar	315bar	2.51mm	34CrMo4	34B	16 × 13 × 56cm
5Kg	φ 138mm	6.67L	600mm	8.6Kg	14Kg	5Kg				3.30mm		89B	21 × 15 × 73cm



# 手提式干粉灭火器

## Portable Dry Powder Fire Extinguisher



# 手提式干粉灭火器

## Portable Dry Powder Fire Extinguisher



### 手提式干粉灭火器(常规带底圈)

Portable Dry Powder Fire Extinguisher(With Foot Ring)

规格	外径	容积	瓶高	瓶重	灭火器重量	灭火剂重量	温度范围	最大工作压力	测试压力	最小壁厚	材料	灭火级别	包装尺寸
Spec.	Out-diameter	Volume	Cylinder Length	Cylinder Weight	Extinguisher Weight	Filling Weight	Temperature Range	Max.Working Pressure	Test Pressure	Min.Wall-thickness	Material	Fire Class	Packing Size
0.5Kg	Φ66mm	0.68L	245mm	0.4Kg	1.2Kg	0.5Kg	-30℃~+60℃	18bar	27bar	0.70mm	DC01/St12	5A 21B C	7.5×7.5×32cm
1Kg	Φ90mm	1.2L	235mm	0.65Kg	1.9Kg	1Kg				0.80mm		8A 34B C	11×11×34cm
2Kg	Φ110mm	2.4L	310mm	1.1Kg	3.4Kg	2Kg				1.07mm		13A 55B C	13×13×41cm
2.3Kg	Φ110mm	2.7L	335mm	1.2Kg	3.8Kg	2.3Kg				1.07mm		13A 55B C	13×13×44cm
3Kg	Φ130mm	3.5L	320mm	1.7Kg	5.1Kg	3Kg				1.14mm		13A 70B C	16×14×43cm
4Kg	Φ130mm	4.7L	415mm	2.1Kg	6.5Kg	4Kg				1.14mm		21A 113B C	16×14×51cm
4.5Kg	Φ150mm	5.3L	360mm	2.1Kg	7.0Kg	4.5Kg				1.20mm		21A 113B C	16×16×46cm
5Kg	Φ150mm	5.9L	400mm	2.3Kg	7.7Kg	5Kg				1.20mm		21A 144B C	16×16×50cm
6Kg	Φ163mm	7.2L	410mm	2.7Kg	9.1Kg	6Kg				1.25mm		27A 183B C	17×17×51cm
6.8Kg	Φ163mm	8.0L	450mm	2.9Kg	10.1Kg	6.8Kg				1.25mm		27A 183B C	17×17×55c
8Kg	Φ163mm	9.1L	505mm	3.2Kg	11.7Kg	8Kg				1.25mm		34A 183B C	17×17×61cm
9Kg	Φ180mm	10.7L	490mm	3.5Kg	13.1Kg	9Kg				1.30mm		34A 233B C	19×19×60cm
10Kg	Φ180mm	11.8L	530mm	4.2Kg	14.7Kg	10Kg				1.30mm		43A 233B C	19×19×64cm
12Kg	Φ180mm	13.4L	600mm	4.7Kg	17.2Kg	12Kg	1.30mm	55A 233B C	19×19×71cm				

### 手提式干粉灭火器(外置式)

Portable Dry Powder Fire Extinguisher(With External Gas Cartridge)

规格	外径	容积	瓶高	瓶重	灭火器重量	灭火剂重量	温度范围	最大工作压力	测试压力	最小壁厚	材料	灭火级别	包装尺寸	内置小钢瓶	
														Internal Gas Cartridge	材料
Spec.	Out-diameter	Volume	Cylinder Length	Cylinder Weight	Extinguisher Weight	Filling Weight	Temperature Range	Max. Working Pressure	Test Pressure	Min.Wall-thickness	Material	Fire Class	Packing Size	驱动气体	材料
6Kg	Φ160mm	7.4L	440mm	3.1Kg	11.3Kg	6Kg	-30℃~+60℃	18bar	27bar	1.24mm	DC01/St12	27A 183B C	24×19×51cm	CO <sub>2</sub> (250g)	20#
8Kg	Φ170mm	9.5L	485mm	3.7Kg	14.1Kg	8Kg				1.27mm		34A 183B C	24×21×57cm	CO <sub>2</sub> (280g)	20#
9Kg	Φ180mm	11.3L	520mm	4.6Kg	16.0Kg	9Kg				1.30mm		34A 233B C	24×22×62cm	CO <sub>2</sub> (300g)	20#
10Kg	Φ180mm	11.8L	540mm	4.7Kg	16.5Kg	10Kg				1.30mm		43A 233B C	24×22×66cm	CO <sub>2</sub> (300g)	20#
12Kg	Φ180mm	13.8L	630mm	5.1Kg	19.6Kg	12Kg				1.30mm		55A 233B C	24×22×79cm	CO <sub>2</sub> (350g)	20#





# 手提式CO2灭火器(铝合金)

## Portable CO2 Fire Extinguisher(Aluminum-alloy)



# 手提式CO2灭火器(铝合金)

## Portable CO2 Fire Extinguisher(Aluminum-alloy)



### 手提式CO2灭火器(铝合金)

#### Portable CO2 Fire Extinguisher(Aluminum-alloy)

规格	外径	容积	瓶高	瓶重	灭火器重量	灭火剂重量	温度范围	最大工作压力	测试压力	最小壁厚	材料	灭火级别	包装尺寸
Spec.	Out-diameter	Volume	Cylinder Length	Cylinder Weight	Extinguisher Weight	Filling Weight	Temperature Range	Max.Working Pressure	Test Pressure	Min.Wall-thickness	Material	Fire Class	Packing Size
1Kg	Φ111mm	1.5L	275mm	2Kg	3.7Kg	1Kg	-20℃~+60℃	174bar	250bar	6.32mm	AA6061	21B	16 × 13 × 39.5cm
2Kg	Φ111mm	3L	475mm	3.2Kg	6Kg	2Kg				6.32mm		34B	16 × 13 × 59.5cm
3Kg	Φ140mm	4.5L	440mm	4Kg	8Kg	3Kg				6.5mm		34B	21 × 15 × 56cm
4Kg	Φ140mm	6L	560mm	6.5Kg	11.6Kg	4Kg				6.5mm		70B	21 × 15 × 68cm
5Kg	Φ159mm	7.5L	560mm	6.7Kg	13Kg	5Kg				7.38mm		89B	22 × 17 × 68cm
6Kg	Φ159mm	9L	680mm	9.6kg	16.7Kg	6Kg				7.38mm		89B	22 × 17 × 80cm



# 手提式CO2灭火器

## Portable CO2 Fire Extinguisher



# 手提式CO2灭火器

## Portable CO2 Fire Extinguisher



### 手提式CO2灭火器(合金钢)

Portable CO2 Fire Extinguisher(Alloy-steel)

规格 Spec.	外径 Out-diameter	容积 Volume	瓶高 Cylinder Length	瓶重 Cylinder Weight	灭火器重量 Extinguisher Weight	灭火剂重量 Filling Weight	温度范围 Temperature Range	最大工作压力 Max.Working Pressure	测试压力 Test Pressure	最小壁厚 Min.Wall-thickness	材料 Material	灭火级别 Fire Class	包装尺寸 Packing Size
2Kg	φ 105mm	3L	475mm	4.9Kg	7Kg	2Kg	-20℃~ +60℃	174bar	250bar	2.3mm	34CrMo4	34B	16 × 13 × 60cm
3Kg	φ 138mm	4.5L	440mm	6.4Kg	11Kg	3Kg				3.0mm		34B	21 × 15 × 56cm
4.5Kg	φ 138mm	6.8L	600mm	8.0Kg	14Kg	4.5Kg				3.0mm		70B	21 × 15 × 73cm
5Kg	φ 138mm	7.5L	655mm	9.3Kg	15Kg	5Kg				3.0mm		89B	21 × 15 × 78cm

### 手提式CO2灭火器(碳钢)

Portable CO2 Fire Extinguisher(Carbon-steel)

规格 Spec.	外径 Out-diameter	容积 Volume	瓶高 Cylinder Length	瓶重 Cylinder Weight	灭火器重量 Extinguisher Weight	灭火剂重量 Filling Weight	温度范围 Temperature Range	最大工作压力 Max.Working Pressure	测试压力 Test Pressure	最小壁厚 Min.Wall-thickness	材料 Material	灭火级别 Fire Class	包装尺寸 Packing Size
1.3Kg	φ 114mm	2L	320mm	4.5Kg	6.5Kg	1.3Kg	-20℃~ +60℃	174bar	250bar	3.68mm	45/CK45	21B	17 × 13 × 45cm
2Kg	φ 114mm	3L	415mm	5.7Kg	8.5Kg	2Kg				3.68mm		34B	17 × 13 × 55cm
2.3Kg	φ 114mm	3.5L	470mm	6.5Kg	10Kg	2.3Kg				3.68mm		34B	17 × 13 × 60cm
3Kg	φ 114mm	4.5L	605mm	8Kg	11.7Kg	3Kg				3.68mm		34B	17 × 13 × 73cm
4Kg	φ 152mm	6L	480mm	11Kg	16Kg	4Kg				4.9mm		70B	21 × 17 × 60cm
4.5Kg	φ 152mm	6.8L	520mm	12Kg	17.5Kg	4.5Kg				4.9mm		70B	21 × 17 × 65cm
5Kg	φ 152mm	7.5L	570mm	13Kg	19Kg	5Kg				4.9mm		89B	21 × 17 × 71cm
6Kg	φ 152mm	9L	670mm	15Kg	22Kg	6Kg				4.9mm		89B	21 × 17 × 79cm
7Kg	φ 152mm	10.5L	770mm	17Kg	25Kg	7Kg				4.9mm		113B	21 × 17 × 89cm
9Kg	φ 152mm	13.5L	980mm	20Kg	30Kg	9Kg				4.9mm		113B	21 × 17 × 110cm



**手提式灭火器(不锈钢)**  
Portable Fire Extinguisher(Stainless Steel)



**手提式灭火器(不锈钢)**  
Portable Fire Extinguisher(Stainless Steel)



**手提式干粉灭火器(不锈钢)**  
Portable Dry Powder Fire Extinguisher(Stainless Steel)

规格	外径	容积	瓶高	瓶重	灭火器重量	灭火剂重量	温度范围	最大工作压力	测试压力	最小壁厚	材料	灭火级别	包装尺寸
Spec.	Out-diameter	Volume	Cylinder Length	Cylinder Weight	Extinguisher Weight	Filling Weight	Temperature Range	Max.Working Pressure	Test Pressure	Min.Wall-thickness	Material	Fire Class	Packing Size
1Kg	φ89mm	1.3L	250mm	0.6Kg	1.8Kg	1Kg	-30℃~+60℃	18bar	27bar	0.64mm	SUS304	8A 34B C	10 × 10 × 35cm
2Kg	φ110mm	2.5L	302mm	1.0Kg	3.3Kg	2Kg				0.64mm		13A 55B C	13 × 13 × 40cm
4Kg	φ130mm	4.7L	412mm	1.5Kg	6.0Kg	4Kg				0.64mm		21A 113B C	15 × 14 × 51cm
6Kg	φ160mm	8.0L	448mm	2.0Kg	9.0Kg	6Kg				0.64mm		27A 183B C	17 × 17 × 56cm
9Kg	φ180mm	12.5L	500mm	2.6Kg	12.5Kg	9Kg				0.64mm		34A 233B C	19 × 19 × 61cm

**手提式泡沫灭火器(不锈钢)**  
Portable Foam Fire Extinguisher(Stainless Steel)

规格	外径	容积	瓶高	瓶重	灭火器重量	灭火剂重量	温度范围	最大工作压力	测试压力	最小壁厚	材料	灭火级别	包装尺寸
Spec.	Out-diameter	Volume	Cylinder Length	Cylinder Weight	Extinguisher Weight	Filling Weight	Temperature Range	Max.Working Pressure	Test Pressure	Min.Wall-thickness	Material	Fire Class	Packing Size
4L	φ150mm	5.4L	380mm	1.6Kg	6.0Kg	4L	+5℃~+60℃	18bar	27bar	0.64mm	SUS304	8A 70B	15 × 14 × 51cm
6L	φ160mm	7.9L	440mm	2.0Kg	9.0Kg	6L				0.64mm		13A 113B C	17 × 17 × 56cm
9L	φ180mm	13.5L	535mm	2.8Kg	12.7Kg	9L				0.64mm		34A 233B C	19 × 19 × 65cm





**悬挂式干粉灭火器**  
Ceiling Dry Powder Fire Extinguisher

规格 Spec.	外径 Out-diameter	容积 Volume	瓶高 Cylinder Length	瓶重 Cylinder Weight	灭火器重量 Extinguisher Weight	灭火剂重量 Filling Weight	温度范围 Temperature Range	最大工作压力 Max. Working Pressure	测试压力 Test Pressure	最小壁厚 Min. Wall-thickness	材料 Material	灭火级别 Fire Class	包装尺寸 Packing Size
3Kg	φ240mm	4.4L	156mm	2.0Kg	5.4Kg	3Kg	-10℃~ +50℃	14bar	25bar	1.50mm	DC01/St12	8A 34B C	25 × 25 × 23cm
4.5Kg	φ194mm	5.5L	254mm	2.2Kg	7.1Kg	4.5Kg				1.35mm		13A 89B C	20.5 × 20.5 × 33cm
6Kg	φ290mm	7.6L	197mm	3.2Kg	9.6Kg	6Kg				1.67mm		27A 113B C	30 × 30 × 33cm
9Kg	φ302mm	11.4L	237mm	4.2Kg	13.6Kg	9Kg				1.30mm		34A 144B C	31 × 31 × 31cm
12Kg	φ370mm	15.0L	247mm	6.6Kg	19.0Kg	12Kg				2.05mm		43A 183B C	38 × 38 × 37cm





**推车式干粉灭火器**   
Mobile Dry Powder Fire Extinguisher

规格	外径	容积	瓶高	瓶重	灭火器重量	灭火剂重量	温度范围	最大工作压力	测试压力	最小壁厚	材料	灭火级别	包装尺寸
Spec.	Out-diameter	Volume	Cylinder Length	Cylinder Weight	Extinguisher Weight	Filling Weight	Temperature Range	Max.Working Pressure	Test Pressure	Min.Wall-thickness	Material	Fire Class	Packing Size
25Kg	Φ270mm	30.5L	626mm	13.2Kg	59Kg	25Kg	-30℃~+60℃	15bar	35bar	2.1mm	HP295	55A I B C	58 × 45 × 98cm
50Kg	Φ320mm	60.5L	875mm	21.2Kg	95Kg	50Kg				2.4mm		55A II B C	64 × 49 × 110cm
100Kg	Φ406mm	124.5L	1100mm	40.8Kg	180Kg	100Kg				2.8mm	HP325	55A III B C	79 × 58 × 150cm

**推车式泡沫灭火器**   
Mobile Foam Fire Extinguisher

规格	外径	容积	瓶高	瓶重	灭火器重量	灭火剂重量	温度范围	最大工作压力	测试压力	最小壁厚	材料	灭火级别	包装尺寸
Spec.	Out-diameter	Volume	Cylinder Length	Cylinder Weight	Extinguisher Weight	Filling Weight	Temperature Range	Max.Working Pressure	Test Pressure	Min.Wall-thickness	Material	Fire Class	Packing Size
25L	Φ270mm	29.5L	626mm	14.2Kg	60Kg	25L	+5℃~+60℃	15bar	35bar	2.1mm	HP295	55A I B C	58 × 45 × 98cm
50L	Φ320mm	59.0L	875mm	22.2Kg	96Kg	50L				2.4mm		55A II B C	64 × 49 × 110cm
100L	Φ406mm	123.5L	1100mm	43.8Kg	182Kg	100L				2.8mm	HP325	55A III B C	79 × 58 × 150cm

**推车式干粉灭火器(焊接型)**  
Mobile Dry Powder Fire Extinguisher(Welding Type)

规格	外径	容积	瓶高	瓶重	灭火器重量	灭火剂重量	温度范围	最大工作压力	测试压力	最小壁厚	材料	灭火级别	包装尺寸
Spec.	Out-diameter	Volume	Cylinder Length	Cylinder Weight	Extinguisher Weight	Filling Weight	Temperature Range	Max.Working Pressure	Test Pressure	Min.Wall-thickness	Material	Fire Class	Packing Size
25Kg	Φ270mm	30.5L	626mm	20Kg	55Kg	25Kg	-30℃~+60℃	15bar	35bar	2.1mm	HP295	55A I B C	54 × 45 × 95cm
50Kg	Φ320mm	60.5L	875mm	32Kg	91Kg	50Kg				2.4mm		55A II B C	63 × 50 × 111cm
100Kg	Φ406mm	124.5L	1100mm	50Kg	160Kg	100Kg				2.8mm	HP325	55A III B C	65 × 58 × 122cm

**推车式泡沫灭火器(焊接型)**  
Mobile Foam Fire Extinguisher (Welding Type)

规格	外径	容积	瓶高	瓶重	灭火器重量	灭火剂重量	温度范围	最大工作压力	测试压力	最小壁厚	材料	灭火级别	包装尺寸
Spec.	Out-diameter	Volume	Cylinder Length	Cylinder Weight	Extinguisher Weight	Filling Weight	Temperature Range	Max.Working Pressure	Test Pressure	Min.Wall-thickness	Material	Fire Class	Packing Size
25L	Φ270mm	30.0L	626mm	20Kg	55.5Kg	25L	+5℃~+60℃	15bar	35bar	2.1mm	HP295	55A I B C	58 × 45 × 98cm
50L	Φ320mm	60.0L	875mm	32Kg	93Kg	50L				2.4mm		55A II B C	64 × 49 × 110cm
100L	Φ406mm	124.0L	1100mm	50Kg	162Kg	100L				2.8mm	HP325	55A III B C	79 × 58 × 150cm



**推车式灭火器(外置式)**  
Mobile Fire Extinguisher(With External Gas Cartridge)



**推车式灭火器(外置式)**  
Mobile Fire Extinguisher(With External Gas Cartridge)



**推车式干粉灭火器(外置式)**  
Mobile Dry Powder Fire Extinguisher(With External Gas Cartridge)

规格 Spec.	外径 Out-diameter	容积 Volume	瓶高 Cylinder Length	瓶重 Cylinder Weight	灭火器重量 Extinguisher Weight	灭火剂重量 Filling Weight	温度范围 Temperature Range	最大工作压力 Max. Working Pressure	测试压力 Test Pressure	最小壁厚 Min. Wall-thickness	材料 Material	灭火级别 Fire Class	包装尺寸 Packing Size	外置小钢瓶 External Gas Cartridge	
														驱气体 Drive gas	材料 Material
25Kg	Φ270mm	30.5L	626mm	20Kg	60Kg	25Kg	-30℃ ~+60℃	24bar	35bar	2.1mm	HP295	55A   BC	54 x 45 x 95cm	CO <sub>2</sub> (0.67Kg)	CK45
50Kg	Φ320mm	60.5L	875mm	32Kg	100Kg	50Kg				2.4mm		55A II BC	63 x 50 x 111cm	CO <sub>2</sub> (1.25Kg)	CK45
100Kg	Φ406mm	124.5L	1100mm	50Kg	180Kg	100Kg				2.8mm	HP325	55A III BC	65 x 58 x 122cm	CO <sub>2</sub> (2.5Kg)	CK45

**推车式泡沫灭火器(外置式)**  
Mobile Foam Fire Extinguisher(With External Gas Cartridge)

规格 Spec.	外径 Out-diameter	容积 Volume	瓶高 Cylinder Length	瓶重 Cylinder Weight	灭火器重量 Extinguisher Weight	灭火剂重量 Filling Weight	温度范围 Temperature Range	最大工作压力 Max. Working Pressure	测试压力 Test Pressure	最小壁厚 Min. Wall-thickness	材料 Material	灭火级别 Fire Class	包装尺寸 Packing Size	外置小钢瓶 External Gas Cartridge	
														驱气体 Drive gas	材料 Material
25L	Φ270mm	30.0L	626mm	20Kg	60Kg	25L	+5℃ ~+60℃	24bar	35bar	2.1mm	HP295	55A   BC	54 x 45 x 95cm	CO <sub>2</sub> (0.46Kg)	CK45
50L	Φ320mm	60.0L	875mm	32Kg	100Kg	50L				2.4mm		55A II BC	63 x 50 x 111cm	CO <sub>2</sub> (1.0Kg)	CK45
100L	Φ406mm	124.0L	1100mm	50Kg	180Kg	100L				2.8mm	HP325	55A III BC	65 x 58 x 122cm	CO <sub>2</sub> (2.0Kg)	CK45





**推车式CO2灭火器(碳钢)**  
Mobile CO2 Fire Extinguisher(Carbon-steel)

规格	外径	容积	瓶高	瓶重	灭火器重量	灭火剂重量	温度范围	最大工作压力	测试压力	最小壁厚	材料	灭火级别	包装尺寸
Spec.	Out-diameter	Volume	Cylinder Length	Cylinder Weight	Extinguisher Weight	Filling Weight	Temperature Range	Max.Working Pressure	Test Pressure	Min.Wall-thickness	Material	Fire Class	Packing Size
10Kg (5×2)	φ152mm	15(7.5×2)L	570mm	25Kg	50Kg	10Kg	-20℃~+60℃	174bar	250bar	4.9mm	45/CK45	183B	30×46×85cm
10Kg	φ152mm	15L	1070mm	25Kg	46Kg	10Kg				4.9mm	45/CK45	183B	46×30×120cm

**推车式CO2灭火器(锰钢)**  
Mobile CO2 Fire Extinguisher(Carbon-manganese-steel)

规格	外径	容积	瓶高	瓶重	灭火器重量	灭火剂重量	温度范围	最大工作压力	测试压力	最小壁厚	材料	灭火级别	包装尺寸
Spec.	Out-diameter	Volume	Cylinder Length	Cylinder Weight	Extinguisher Weight	Filling Weight	Temperature Range	Max.Working Pressure	Test Pressure	Min.Wall-thickness	Material	Fire Class	Packing Size
20Kg	φ219mm	33.5L	1140mm	43Kg	93Kg	20Kg	-20℃~+55℃	150bar	225bar	5.0mm	37Mn	233B	102×48×122cm
25Kg	φ219mm	40L	1340mm	48Kg	102Kg	25Kg				5.0mm	37Mn	233B	102×48×122cm
50Kg	φ219mm	80(40×2)L	1340mm	96Kg	191Kg	50Kg				5.0mm	37Mn	233B	123×62×132cm





# 正压式消防空气呼吸器

Self-contained positive pressure air breathing apparatus for fire fighter



WINNER



# 正压式消防空气呼吸器

Self-contained positive pressure air breathing apparatus for fire fighter



WINNER

## 正压式消防空气呼吸器(复合气瓶)

Self-contained positive pressure air breathing apparatus for fire fighter (Composite cylinder)

型号 Type	工作压力 Working pressure(MPa)	气瓶公称容积(L) Nominal water capacity (L)	最大供气流量 Max. gas flow(L/min)	呼吸阻力 Exhalation & inhalation resistance(Pa)		报警压力 Alarm pressure(MPa)	使用时间 Using time(min)	整机重量 Total weight(kg)
				呼气 Exhalation resistance	吸气 inhalation resistance			
RHZKF6/30	30	6	300	≤1000	≤500	5-6	45-50	≤8
RHZKF6.8/30	30	6.8	300	≤1000	≤500	5-6	50-60	≤10

## 正压式消防空气呼吸器(钢瓶)

Self-contained positive pressure air breathing apparatus for fire fighter ( Steel cylinder)

型号 Type	工作压力 Working pressure(MPa)	气瓶公称容积(L) Nominal water capacity (L)	最大供气流量 Max. gas flow(L/min)	呼吸阻力 Exhalation & inhalation resistance(Pa)		报警压力 Alarm pressure(MPa)	使用时间 Using time(min)	整机重量 Total weight(kg)
				呼气 Exhalation resistance	吸气 inhalation resistance			
RHZKG 6/30	30	6	300	≤1000	≤500	5-6	45-50	≤16





外置式储气瓶  
External CO2 Gas Cartridge

规格 Type	250g	280g	300g	350g
产品编号 Item No.	WN31-01	WN31-02	WN31-03	WN31-04
外径 Out-diameter(mm)	Φ51	Φ51	Φ51	Φ51
容积 Volume(ml)	375	420	450	525
充装量 CO2 Filled Weight(g)	250	280	300	350
瓶体长度 Cylinder Length(mm)	280	310	330	390
测试压力 Test Pressure(bar)	250	250	250	250
最小壁厚 Min.Wall-thickness(mm)	3	3	3	3
材料 Material	20#	20#	20#	20#



内置式储气瓶  
Internal CO2 Gas Cartridge

规格 Type	55g	75g	120g	180g	225g
产品编号 Item No.	WN32-01	WN32-02	WN32-03	WN32-04	WN32-05
外径 Out-diameter(mm)	Φ38	Φ38	Φ38	Φ40	Φ40
容积 Volume(ml)	82.5	112.5	180	270	338
充装量 CO2 Filled Weight(g)	55	75	120	180	225
瓶体长度 Cylinder Length(mm)	140	170	245	320	385
测试压力 Test Pressure(bar)	250	250	250	250	250
最小壁厚 Min.Wall-thickness(mm)	2	2	2	2	2
材料 Material	20#	20#	20#	20#	20#



内置式储气瓶  
Internal CO2 Gas Cartridge



规格 Type	55g	75g	120g	150g	225g
产品编号 Item No.	WN30-01	WN30-02	WN30-03	WN30-04	WN30-05
外径 Out-diameter(mm)	Φ28	Φ28	Φ35	Φ35	Φ40
容积 Volume(ml)	74	100	160	200	300
充装量 CO2 Filled Weight(g)	55	75	120	150	225
瓶体长度 Cylinder Length(mm)	208	267	255	305	375
测试压力 Test Pressure(bar)	290	290	290	290	290
最小壁厚 Min.Wall-thickness(mm)	1.5	1.5	1.7	1.7	1.95
材料 Material	ST52	ST52	ST52	ST52	ST52





图号 Drawing	瓶口连接螺纹 Inlet thread	吸管连接螺纹 Dip tube thread	喷具连接螺纹 Outlet thread	最大工作压力 Working pressure (bar)	试验压力 Test pressure (bar)	压力泄放装置动作压力 PRD pressure (bar)	工作温度 Working temperature	认证模式 Certificate	
WN52-01-0Rev.1	M25x2	M10x1	W21.8-14	174	250	225 ± 22.5	-30℃ ~ +60℃	CE	
WN52-01A-0Rev.1				169.3	215	200 ± 10		未认证	
WN52-01B-0Rev.1				174	250	225 ± 22.5		CE	
WN52-01C-0Rev.0				169.3	215	200 ± 10		未认证	
WN52-01D-0Rev.0				169.3	215	200 ± 10		未认证	
WN52-01E-0Rev.0				174	250	225 ± 22.5		CE	
WN52-01F-0Rev.0				169.3	215	200 ± 10		未认证	
WN52-04-0Rev.1	25E	M10x1	W21.8-14	174	250	225 ± 22.5	-30℃ ~ +60℃	CE	
WN52-04A-0Rev.1									
WN52-04B-0Rev.1									
WN52-04C-0Rev.1									
WN52-09-0Rev.4	PZ27.8	M10x1	W21.8-14	174	250	225 ± 22.5	-30℃ ~ +60℃	未认证	
WN52-09A-0Rev.5									
WN52-20-0Rev.7	PZ27.8	M10x1	W21.8-14	174	250	225 ± 22.5	-30℃ ~ +60℃	未认证	
WN52-21-0Rev.1									
WN52-21A-0Rev.1	M25x2	M10x1	W21.8-14	174	250	225 ± 22.5	-30℃ ~ +60℃	CE	
WN52-21B-0Rev.1									
WN52-21C-0Rev.0									
WN52-22-0Rev.2	M25x2	M10x1	W21.8-14	170	215	200 ± 10	-30℃ ~ +60℃	CE	
WN52-22A-0Rev.3				170				CE	
WN52-22B-0Rev.1				169.3				未认证	
WN52-22C-0Rev.1				170				CE	
WN52-23-0Rev.7	PZ27.8	M10x1	W21.8-14	174	250	225 ± 22.5	-30℃ ~ +60℃	未认证	
WN52-25-0Rev.3	25E	M10x1	W21.8-14	174	250	225 ± 22.5	-30℃ ~ +60℃	CE	
WN52-25A-0Rev.2									
WN52-25B-0Rev.1									
WN52-25D-0Rev.1									
WN52-25E-0Rev.0									
WN52-25G-0Rev.0	G1/4-19								
WN52-26-0Rev.2	25E	M10x1	W21.8-14	174	250	225 ± 22.5	-30℃ ~ +60℃	CE	
WN52-26B-0Rev.1		G1/4-19							
WN52-29-0Rev.0	M25x2	M10x1	M22x1.5	166	250	190 ± 15	-10℃ ~ +55℃	未认证	
WN52-30-0Rev.3	PZ27.8	M10x1	W21.8-14	174	250	225 ± 22.5	-30℃ ~ +60℃	未认证	
WN52-31-0Rev.2	W28.8-14	M10x1	W21.8-14	174	250	200 ± 20	-30℃ ~ +60℃	未认证	
WN52-33-0Rev.1	M25x2	M14x1.5	W21.8-14	174	250	225 ± 22.5	-30℃ ~ +60℃	CE	
WN52-36-0Rev.2	25E	M14x1.5	W21.8-14	216	315	265 ± 26.5	-30℃ ~ +60℃		
WN52-36A-0Rev.1	25E	M10x1	W21.8-14	216	315	265 ± 26.5	-30℃ ~ +60℃		
WN52-36B-0Rev.1	25E	G1/4-19	W21.8-14	216	315	265 ± 26.5	-30℃ ~ +60℃		
WN52-36C-0Rev.1	W28.8-14	M10x0.75	W21.8-14	216	315	265 ± 26.5	-30℃ ~ +60℃		
WN52-37-0Rev.0	M25x2	M14x1.5	W21.8-14	216	315	265 ± 26.5	-30℃ ~ +60℃		
WN52-38-0Rev.2	25E	M10x1	W21.8-14	174	250	225 ± 22.5	-30℃ ~ +60℃		
WN52-39-0Rev.3	25E	M10x1	W21.8-14	174	250	225 ± 22.5	-30℃ ~ +60℃		
WN52-43-0Rev.1	PZ27.8	M10x1	M22x1.5	170	255	170 ~ 255	-20℃ ~ +55℃		内销
WN52-44-0Rev.3	PZ27.8	M10x1	W21.8-14	174	250	225 ± 22.5	-30℃ ~ +60℃		未认证
WN52-45-0Rev.2	25E	M10x1	W21.8-14	174	250	225 ± 22.5	-30℃ ~ +60℃	CE	
WN52-46-0Rev.0	PZ27.8	M10x1	M22x1.5	170	255	170 ~ 255	-20℃ ~ +55℃	内销	





WN50-09-0Rev.2



WN50-15-0Rev.3



WN50-16-0Rev.0



WN51-12-0Rev.1



WN51-14-0Rev.2



WN51-20-0Rev.3



WN51-21-0Rev.1



WN51-22-0Rev.2



WN51-24-0Rev.1



WN51-34-0Rev.2



WN51-36-0Rev.0



WN51-38-0Rev.2

图号 Drawing	瓶口连接 螺纹 Inlet thread	吸管连接 螺纹 Dip tube thread	喷具连接 螺纹 Outlet thread	压力表连接 螺纹 Pressure gauge thread	最大工作压力 Working pressure (bar)	试验压力 Test pressure (bar)	压力泄放装置 动作压力 PRD Pressure(bar)	工作温度 Working temperature	认证模式 Certificate		
WN50-09-0Rev.2	M30x1.5	M16x1.5	G1/8	M10x1	18	27	19 - 26	-30℃ ~ +60℃	CE		
WN50-09A-0Rev.2											
WN50-09B-0Rev.2											
WN50-09C-0Rev.2											
WN50-09D-0Rev.0											
WN50-09E-0Rev.0											
WN50-09F-0Rev.2											
WN50-09G-0Rev.2											
WN50-09L-0Rev.2										26	38
WN50-09K-0Rev.0										18	27
WN50-09T-0Rev.0										26	38
WN50-09S-0Rev.0										M24x1.5	M14x1.5
WN50-15-0Rev.3	/	-20℃ ~ +55℃	内销								
WN50-15A-0Rev.0	20	30	/	-20℃ ~ +55℃	内销						
WN50-16-0Rev.0	M24x1.5	M14x1.5	M12x1.5	M10x1	20	30	/	-20℃ ~ +55℃	内销		
WN51-12-0Rev.1	M30x1.5	M16x1.5	G1/4	M10x1	18	27	19 - 26	-30℃ ~ +60℃	CE		
WN51-12A-0Rev.1											
WN51-12B-0Rev.1											
WN51-12C-0Rev.1											
WN51-12D-0Rev.3											
WN51-12E-0Rev.1											
WN51-12F-0Rev.0											
WN51-12G-0Rev.0											
WN51-12H-0Rev.0											
WN51-12L-0Rev.0											
WN51-12K-0Rev.0											
WN51-14-0Rev.2										M30x1.5	M16x1.5
WN51-14A-0Rev.2											
WN51-14B-0Rev.1											
WN51-14C-0Rev.0											
WN51-20-0Rev.3	M30x1.5	M16x1.5	M14x1.5	M10x1	18	27	/	-30℃ ~ +60℃	未认证		
WN51-21-0Rev.1			M16x1.5								
WN51-21B-0Rev.1			M16x1.5								
WN51-21C-0Rev.1	M30x1.5	M16x1.5	G1/4	M10x1	18	27	19 - 26	-30℃ ~ +60℃	CE		
WN51-22-0Rev.2											
WN51-22A-0Rev.2											
WN51-22B-0Rev.2											
WN51-22C-0Rev.2											
WN51-22D-0Rev.3											
WN51-22F-0Rev.0											
WN51-22H-0Rev.0											



**水基、干粉低压阀门**  
Water-based, Dry powder Low pressure valve

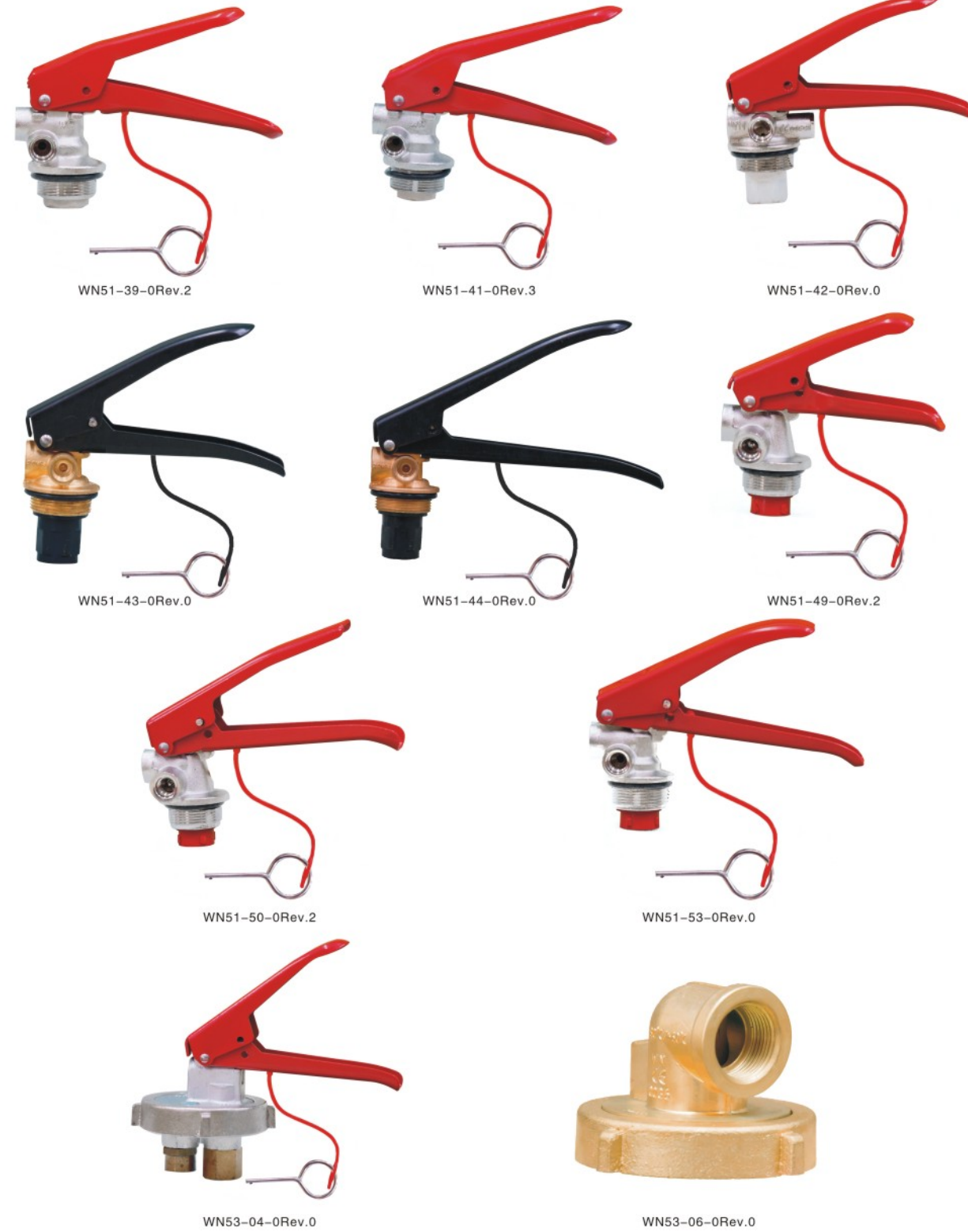

**水基、干粉低压阀门**  
Water-based, Dry powder Low pressure valve



图号 Drawing	瓶口连接 螺纹 Inlet thread	吸管连接 螺纹 Dip tube thread	喷具连接 螺纹 Outlet thread	压力表连接 螺纹 Pressure gauge thread	最大工作压力 Working pressure (bar)	试验压力 Test pressure (bar)	压力泄放装置 动作压力 PRD Pressure(bar)	工作温度 Working temperature	认证模式 Certificate				
WN51-24-0Rev.1	M30x1.5	M16x1.5	G1/8	M10x1	18	27	/	-30℃ ~ +60℃	未认证				
WN51-26-0Rev.4			M16x1.5										
WN51-27-0Rev.1			M14x1.5										
WN51-27A-0Rev.1			M12x1.5										
WN51-28-0Rev.0			M12x1.5										
WN51-28A-0Rev.0			M12x1.5										
WN51-29-0Rev.1			G1/4										
WN51-29A-0Rev.0					18	27	19 - 26	-30℃ ~ +60℃	CE				
WN51-34-0Rev.2	M30x1.5	M16x1.5	G1/4	M10x1	18	27	19 - 26	-30℃ ~ +60℃	CE				
WN51-34A-0Rev.1													
WN51-34B-0Rev.0													
WN51-34C-0Rev.0													
WN51-34D-0Rev.0													
WN51-34E-0Rev.0													
WN51-34G-0Rev.1													
WN51-34H-0Rev.0													
WN51-34J-0Rev.0													
WN51-34K-0Rev.0													
WN51-34Q-0Rev.1													
WN51-34T-0Rev.0													
WN51-34S-0Rev.0													
WN51-36-0Rev.0										M30x1.5	M16x1.5	M16x1.5	NPT 1/8
WN51-37-0Rev.0	G1/8	20	30	/	-20℃ ~ +55℃	内销							
WN51-38-0Rev.2	G1/4	18	27	19 - 26	-30℃ ~ +60℃	未认证							
WN51-39-0Rev.2	G1/4					未认证							
WN51-41-0Rev.3	G1/4					未认证							
WN51-42-0Rev.0	M14x1.5					CE							
WN51-42A-0Rev.1	M14x1.5	未认证											
WN51-42B-0Rev.0	M14x1.5	未认证											
WN51-43-0Rev.0	M16x1.5	20	30	/	-20℃ ~ +55℃	内销							
WN51-43B-0Rev.0	M16x1.5	20	30	/	-20℃ ~ +55℃	内销							
WN51-44-0Rev.0	M16x1.5	20	30	/	-20℃ ~ +55℃	内销							
WN51-46-0Rev.0	M45x1.5	M16x1.5	M16x1.5	M10x1	18	27	22 - 27	-30℃ ~ +60℃	CE				
WN51-49-0Rev.2	M30x1.5						G1/8		/	/	/	/	未认证
WN51-50-0Rev.2							G1/8						
WN51-51-0Rev.0							M16x1.5						
WN51-53-0Rev.0							M16x1.5						
WN53-04-0Rev.0	M74x2						M16x1.5		/	33	18 - 22	CE	
WN51-55-0Rev.0	M30x1.5	G 1/4	M16x1.5	M10x1	18	27	/	-30℃ ~ +60℃	CE				
WN53-06-0Rev.0	M74x2	G 3/4	G 3/4	/	26	38	18 - 26	-30℃ ~ +60℃	CE				



二氧化碳灭火器喷具总成 CO2 HOSE & HORN



干粉灭火器喷具总成 DRY POWDER HOSE & HORN





水基类灭火器喷具总成 WATER-BASED HOSE & HORN



WN36-01



WN36-02



WN36-03



WN36-04



WN36-05



WN36-06

干粉灭火器挂具 DRY POWDER BRACKET



WN39-01



WN39-02



WN39-03



WN39-04



WN39-05



WN39-06



WN39-07



WN39-08



WN39-09



WN39-10



WN39-11



二氧化碳灭火器挂具 CO2 BRACKET



WN40-01

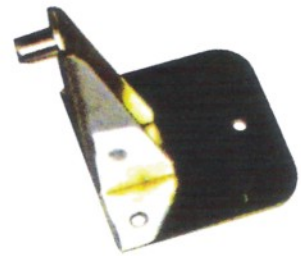

WN40-04



WN40-02

WN40-03



WN40-05

WN40-06

WN40-07

WN40-08

GAUGE 压力表



WN41-01



WN41-02



WN41-03



WN41-04

BASE PLASTIC 灭火器底座



WN42-01



WN42-02



WN42-03



WN42-04

CO2 FIXATION CIRCLER 二氧化碳灭火器固定圈



WN38-01



WN38-02



SPRAY GUN 喷枪总成

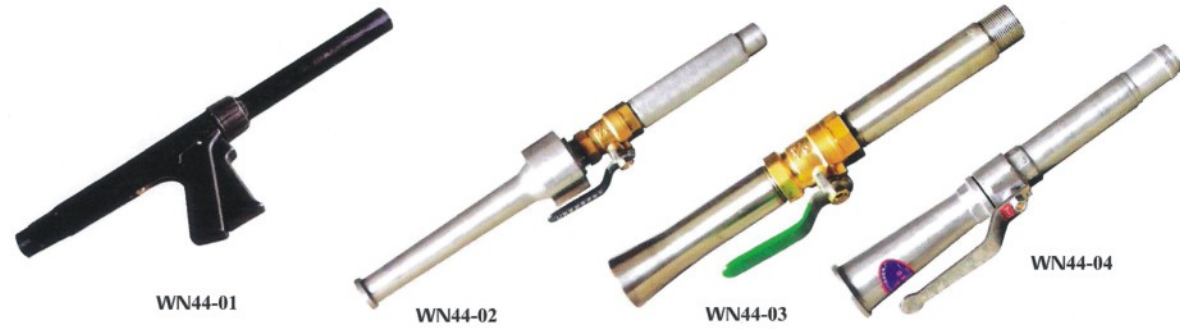

WN44-01

WN44-02

WN44-03

WN44-04

SIPHON 虹吸管  
WN45-01



SEAL 塑封  
WN46-01



WHEEL 车轮  
WN47-01



FIRE BLANKET 灭火毯  
WN48-01



WN49-01

WN49-02



WN49-03

WN49-04

NOZZLE 喷嘴

WN55-07 WN55-08

**WN55-07**  
瓶口连接螺纹 (INLET THERAD): M30X1.5  
装表连接螺纹 (GAUGE CONNECTION THERAD): NPT1/8X27  
公称动作温度 (TEMPERATURE): 68°C  
用气门芯或密封芯 (CHECK VALVE): 气门芯

**WN55-08**  
瓶口连接螺纹 (INLET THERAD): M30X1.5  
装表连接螺纹 (GAUGE CONNECTION THERAD): NPT1/8X27  
公称动作温度 (TEMPERATURE): 68°C  
用气门芯或密封芯 (CHECK VALVE): 锥度关闭

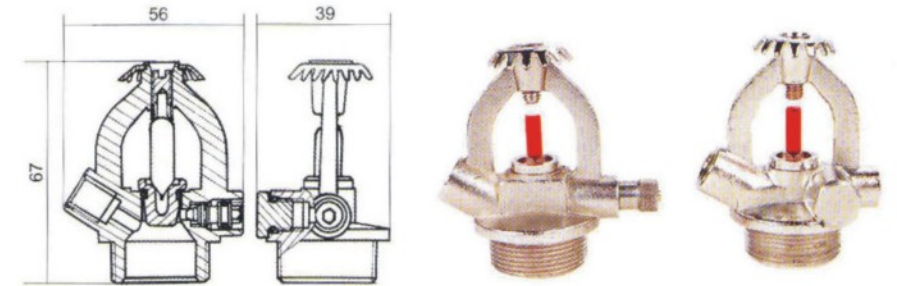

WN55-11

连接螺纹 (INLET THERAD): 1/2BSPT  
公称动作温度 (TEMPERATURE): 57,68,79,93,141°C

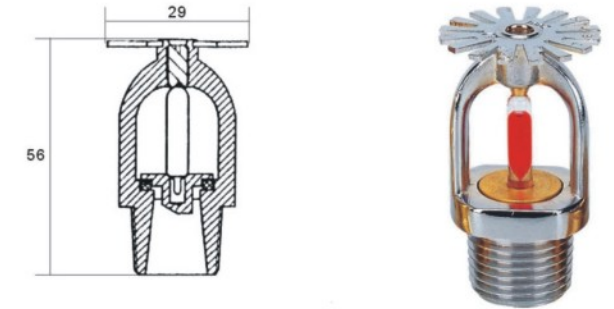

WN55-12

连接螺纹 (INLET THERAD): 1/2BSPT  
公称动作温度 (TEMPERATURE): 57,68,79,93,141°C

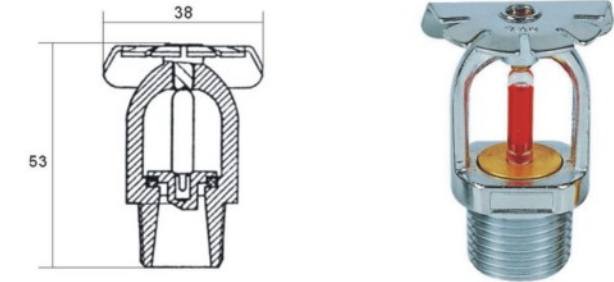

WN55-13

连接螺纹 (INLET THERAD): 1/2BSPT  
公称动作温度 (TEMPERATURE): 57,68,79,93,141°C

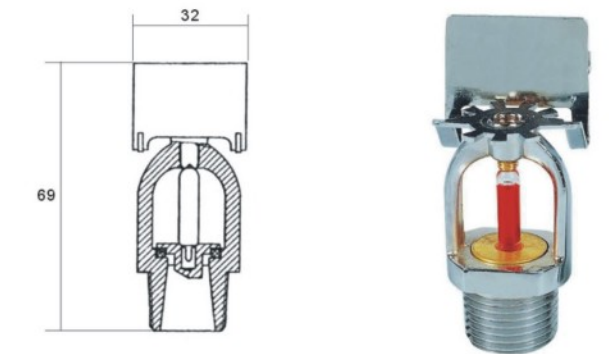



**WN56-01**

3/4" TAIL 30mm;25mm;20mm  
1" TAIL 30mm;25mm;20mm

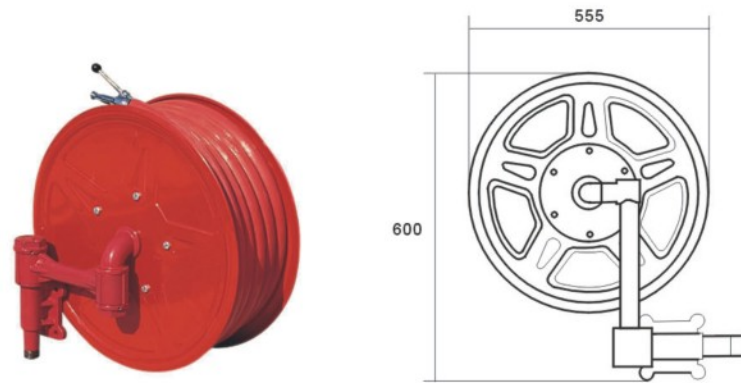

**WN56-02**

3/4" TAIL 30mm;25mm;20mm  
1" TAIL 30mm;25mm;20mm

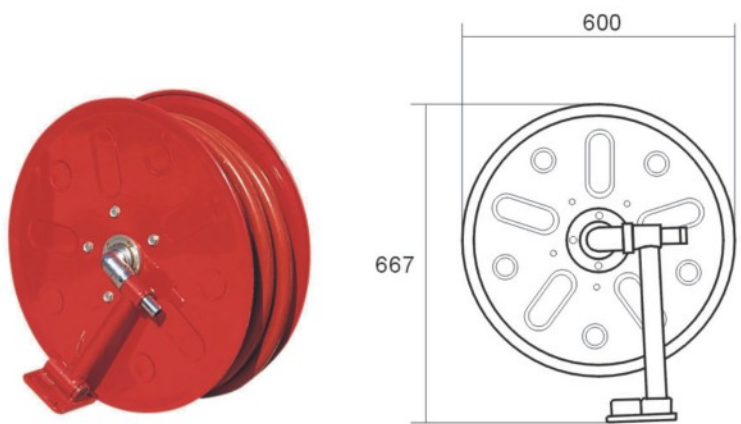

**WN56-03**

3/4" TAIL 30mm;25mm;20mm  
1" TAIL 30mm;25mm;20mm

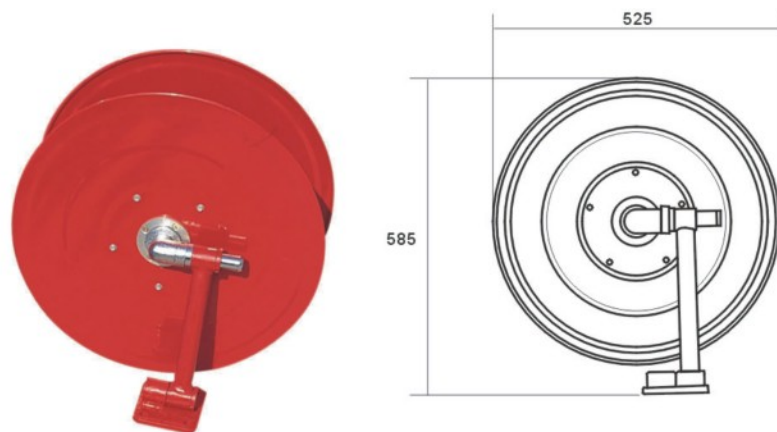

Type	Specification	Weight(g/m)	Working Pressure	Bursing Pressure	Length
C8	40	240	0.8Mpa 8bar 116PSI	≥2.4Mpa 24bar 348PSI	10m-30m
	45	270			
	50	320			
	65	420			
	70	500			
C10	40	250	1.0Mpa 10bar 145PSI	≥3.0Mpa 30bar 435PSI	
	45	290			
	50	330			
	65	420			
	70	520			
	80	550			

Type	Specification	Weight(g/m)	Working Pressure	Bursing Pressure	Length
13	25	110	1.3Mpa 13bar 188.5PSI	≥3.9Mpa 39bar 565.5PSI	10m-100m
	40	130			
	45	165			
	50	190			
	65	250			
	70	265			
	80	320			
	90	420			
	100	490			
	16	25			
40		160			
45		180			
50		210			
65		270			
70		290			
80		350			
90		500			

RUBBER LINING FIRE HOSE

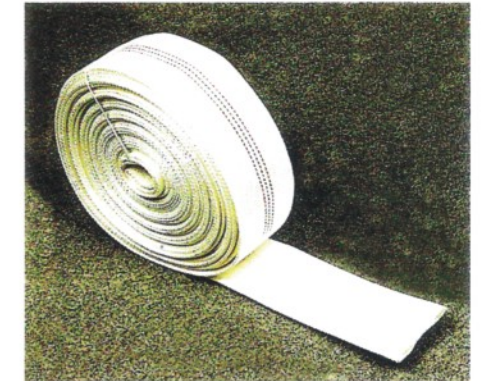

PU LINING FIRE HOSE



SPEC.	W.P	T.P	B.P
1 1/2"	17bar	26bar	51bar
2"	17bar	26bar	51bar
2 1/2"	17bar	26bar	51bar

FIRE HOSE TYPE 3



SPEC.	W.P	T.P	B.P
1 1/2"	13bar	20bar	39bar
2"	13bar	20bar	39bar
2 1/2"	13bar	20bar	39bar

UL APPROVAL FIRE HOSE

